

**ROAR RULES - TABLE OF CONTENTS**  
**REVISION, FEBRUARY 2007**

<b>1</b>	<b>GENERAL RULES.....</b>	<b>3</b>
1.1	GENERAL .....	3
1.2	REVISION POLICY .....	4
1.3	COST CONTROL .....	5
1.4	INDEMNITIES .....	5
1.5	ENVIRONMENT, HEALTH AND SAFETY .....	6
1.6	OFFICIALS .....	8
<b>2</b>	<b>TRACK SPECIFICATIONS .....</b>	<b>9</b>
2.1	BARRIERS .....	9
2.2	RACING FACILITIES.....	11
2.3	RADIO IMPOUND .....	11
2.4	SURFACES .....	12
<b>3</b>	<b>DRIVER RULES.....</b>	<b>12</b>
<b>4</b>	<b>RADIO EQUIPMENT .....</b>	<b>13</b>
<b>5</b>	<b>COMPETITION RULES .....</b>	<b>14</b>
5.1	GENERAL COMPETITION RULES.....	14
5.2	GENERAL VEHICLE RULES .....	15
5.3	CLASSES .....	15
5.4	TECHNICAL INSPECTION .....	16
5.5	TURN MARSHALING .....	18
5.6	SCORING .....	18
5.7	QUALIFYING RULES.....	19
5.8	STARTING – ELECTRIC RACES.....	20
5.9	STARTING – NITRO FUEL RACES .....	20
5.10	FREQUENCY CONFLICTS.....	21
5.11	EVENT ELIGIBILITY.....	21
5.12	BLACK FLAG.....	21
5.13	DISQUALIFICATION .....	22
5.14	PENALTIES .....	23
5.15	PROTESTS .....	25
5.16	AWARDS.....	26
<b>6</b>	<b>BODY, BUMPER AND WING RULES .....</b>	<b>27</b>
6.1	BODY RULES.....	27
6.2	BUMPER RULES .....	28
6.3	SPOILER RULES .....	29
6.4	SIDE DAMS .....	29
6.5	WINGS .....	29
<b>7</b>	<b>WHEEL AND TIRE RULES .....</b>	<b>30</b>
7.1	GENERAL RULES.....	30
7.2	WHEEL RULES .....	30
7.3	TIRE RULES.....	31
	<b>CLASS-SPECIFIC RULES .....</b>	<b>32</b>
<b>8</b>	<b>RULES FOR ELECTRIC CLASSES .....</b>	<b>32</b>
8.1	ELECTRIC RACING RULES .....	32
8.2	GENERAL ELECTRIC VEHICLE RULES .....	32
8.3	BATTERY RULES .....	32
8.4	ELECTRIC MOTOR RULES.....	33

8.5	STOCK MOTOR RULES .....	34
8.6	19T REBUILDABLE "SUPER-STOCK" MOTOR RULES .....	37
8.7	MODIFIED MOTOR RULES .....	40
8.8	19T MODIFIED OVAL MOTOR RULES .....	41
8.9	ELECTRIC VEHICLE CLASS SPECIFICATIONS .....	44
	** GLOBAL BODY SPECIFICATIONS ** .....	49
<b>9</b>	<b>"NITRO" FUEL CLASS RULES.....</b>	<b>55</b>
9.1	FUEL SPECIFICATIONS .....	55
9.2	GENERAL VEHICLE SPECIFICATIONS .....	55
9.3	ENGINE SPECIFICATIONS.....	56
9.4	FUEL VEHICLE CLASS SPECIFICATIONS .....	57
<b>10</b>	<b>RULES FOR 1/5-SCALE FUEL CLASSES .....</b>	<b>68</b>
10.1	BODY RULES – SEDAN AND GT .....	68
10.2	BODY RULES – FORMULA CARS .....	68
10.3	BUMPER RULES – NON-FORMULA CARS .....	68
10.4	ENGINE RULES .....	69
10.5	MUFFLER RULES.....	69
10.6	FUEL RULES.....	70
10.7	TIRE RULES.....	70
10.8	RADIO AND SERVO RULES .....	70
10.9	SAFETY RULES .....	71
10.10	CLASS RULES .....	71
10.11	QUALIFYING RULES .....	74
10.12	RACING RULES .....	74
10.13	PENALTIES .....	74
<b>11</b>	<b>IFMAR WORLD TEAM RULES .....</b>	<b>75</b>
11.1	GENERAL .....	75
11.2	SELECTION POLICY .....	75
<b>12</b>	<b>NATIONALS POLICIES.....</b>	<b>76</b>
12.1	GENERAL .....	76
12.2	ENTRY RULES.....	77
12.3	RACING RULES.....	77
12.4	EQUIPMENT USAGE RULES.....	78
<b>13</b>	<b>CONCOURS RULES.....</b>	<b>81</b>
13.4	GENERAL .....	81
13.5	CATEGORIES FOR BEST APPEARING .....	81
13.6	CATEGORIES FOR MOST AUTHENTIC.....	82
13.7	CONCOURS SCORE SHEET .....	82

# 1 GENERAL RULES

## 1.1 GENERAL

### 1.1.1 Background:

ROAR (Remotely Operated Auto Racers) began in 1967 to promote and regulate radio-controlled auto racing for fuel powered model cars. Over the years, ROAR has developed and refined the rules to govern the racing of both electric and fuel powered cars at ROAR-sanctioned events. These rules have been designed to:

- Guide the development of the sport
- Provide for its growth and welfare
- Establish minimum requirements for participation in the sport
- Ensure fair and equitable application to all aspects of the sport and its participants.

1.1.2 These rules govern the conditions at all ROAR-sanctioned events. ROAR members participating in (or making application to participate in) a ROAR-sanctioned event, ROAR-affiliated clubs or tracks presenting (or making application to present) a ROAR-sanctioned race, and manufacturers making application for the approval of products for use at ROAR-sanctioned events are deemed to have agreed to comply with these rules.

1.1.3 ROAR may act at any time during the preparation for, the running of, or after a ROAR-sanctioned event to change anything that ROAR believes to be contrary to the best interest of the sport or the organization. This includes denying or rescinding ROAR sanction for an event. A ROAR-sanctioned event is a sporting event, and ROAR will always consider the sporting interest before anyone's financial interest, including that of the event organizer.

1.1.4 These rules are the sole property of ROAR. The use of these rules, or of previous versions of these rules by any organization or individual without the prior written consent of ROAR is forbidden. This consent will not be unreasonably withheld, but it must be requested together with sufficient information to assure the ROAR Executive Committee that the use of these rules will not bring ROAR into disrepute.

1.1.5 Any separation of rules into categories is strictly for the convenience of ROAR.

1.1.6 General rules and procedures contained in Sections 1 through 7 of these Rules apply to all classes.

1.1.7 Any addition to the rules and technical specifications mentioned herein, ROAR issues and maintains specific procedures for adherence by promoters, track owners, manufacturers, and affiliated clubs at ROAR-sanctioned events, and procedures governing products submitted to ROAR for approval.

1.1.8 It is the responsibility of members, track owners, and race sponsors to meet all rules and specifications contained in this rulebook, in the National Guidelines for the current year, or issued by ROAR in the Rev-Up Newsletter, in letter form, or posted on the ROAR website.

1.1.9 The use of the words "vehicle" or "vehicles" in these rules is intended to include both cars and trucks.

1.1.10 In the case of a contradiction between a General Rule and a specific class, vehicle type or scale rule, or a rule contained in the ROAR Nationals Guidelines (when a National event), the specific rule will take precedence over, or further clarify the General rule in question.

#### 1.1.11 ROAR-sanctioned races are defined as follows:

- Level 1: Local track races and series;
- Level 2: Multi-city Series Championships and other regional races
- Level 3: Regional and State Championships
- Level 4: Multi-regional Open events
- Level 5: National Championships.

Member tracks are eligible to run any of these races, subject to the sanction procedures in place for the relevant level. It is recommended that a track run a Level 2 event before a Level 3, and a Level 3 event before a Level 4 event.

#### 1.1.12 Sanctioning Procedures:

- Sanction Numbers are issued by the ROAR Competition Director for Level 5 events and by the Regional Directors for Level 2-4 events.
- All entry forms and other advertising for Level 3-5 events must carry the ROAR Sanction number.
- Level 5 events must be sanctioned by the ROAR Executive Committee, under signature of the ROAR Competition Director and in accordance with the selection procedure specified in 12.1.4 below. The term "ROAR National" cannot be used in conjunction with any event that has not been so sanctioned by the Executive Committee.
- Levels 4 events must be sanctioned by the relevant Regional Director and the ROAR Sanctioning Director, by submitting a fully completed Sanction Application Form (available from the ROAR Administrator or on the ROAR website). A Level 4 event is not sanctioned until the event Hosts receive the Sanction Form with the Sanctioning Director signature of approval.
- Level 2 events must be sanctioned by the relevant Regional Director. A fully completed Sanction Form, duly signed by the Regional Director, must be received by the events Host for the event to be sanctioned.
- Level 1 events carry an automatic ROAR sanction under the following conditions:
  - The events are part of a regularly scheduled race program of a ROAR-affiliated Club or Track.
  - All participants in the event (drivers and Officials) are paid up members of ROAR on the date of the event. This includes all single-event memberships and full memberships paid for on the day of the event.

## 1.2 REVISION POLICY

1.2.1 These rules supersede all previous editions of the ROAR rules.

1.2.2 These Rules will be revised as needed, as well as on an annual basis.

1.2.3 A structure of Rules Committees has been established to represent ROAR Members in the formulation and maintenance of the rules contained in this rulebook. The Chairpersons of these Committees are appointed by the President and their contact information is listed on the ROAR website

1.2.4 Members, ROAR Officials, Track Operators, and Industry Affiliates are encouraged to send suggested rules additions or changes directly to the chairpersons of these committees. Proposals or suggestions may be submitted to any member of the ROAR Executive Committee, but these submissions will be referred to the relevant Rules Committee for discussion and acceptance before being reviewed by the ROAR Executive Committee.

- 1.2.5 Suggestions should be in writing and may be sent by E-mail, Fax, or Letter. To the extent possible, a response will be provided for each suggestion. Addresses of key ROAR Officials are listed in Rev-Up, and on the ROAR Website.
- 1.2.6 The ROAR Executive Committee will review all proposals submitted by the Committees and must approve these proposals for them to be included in the ROAR rulebook.
- 1.2.7 Special rulings, changes in technical specifications, or any other changes to these rules between editions of the rule book will not take effect until such rulings or changes are published by ROAR in Rev-Up, another newsletter (such as a posting in a Nationally-distributed magazine), a letter, or posted on the ROAR website. These rulings will be considered as official amendments to this list of rules, procedures and/or specifications.
- 1.2.8 For Level 3-5 events, the final interpretation of any questioned ROAR rule is the responsibility of the Designated ROAR Official for that event. Special rulings may be made by the Designated ROAR Official at an event to amend, suspend, or modify existing rules to account for conditions arising from the location of the event, the condition of the course, weather conditions, or other circumstances requiring such a ruling. Such special rulings will be effective for the event in question only, with no precedence being established for any subsequent event.

**Notes:**

- Underlining of a rule number, text or specification indicates it has been added, moved, or changed since the last rulebook was printed. The number for a deleted rule will be retained and that number underlined to indicate its deletion.
- For IFMAR classes, specifications are provided in Metric units only. For classes that are specific to ROAR, specifications are provided in American units and/or Metric units.

### **1.3 COST CONTROL**

- 1.3.1 ROAR is dedicated to controlling the cost of racing and making it affordable for entry-level drivers to become involved in the sport.
- 1.3.2 Members are encouraged to submit suggestions to the President, Rules Committee Chairperson or ROAR Administrator that will help in controlling or lowering the costs while maintaining a fair playing field.
- 1.3.3 Tracks are encouraged to offer cost controlled classes that will allow new drivers to enter the sport with a minimum investment and others to participate at a reasonable cost.
- 1.3.4 In offering cost controlled classes, tracks may specify the batteries, bodies, chassis, gear ratios, motors, tires, etc that may be used. Care should be taken not to restrict usage of any of these items to a single manufacturer.

### **1.4 INDEMNITIES**

- 1.4.1 No ROAR member, Industry affiliate, event organizer or sponsor, or track owner, will have any claim against ROAR, its agents, officials or employees, for loss or damage of any kind related to or originating from delays, postponements or cancellations of all or part of an event because of inclement weather, equipment failure, or any other reason.

- 1.4.2 No driver, pit crewmember or sponsor will have any claim for damages, expenses, lawsuits, or otherwise against a promoter, track operator, or ROAR, its officials, agents, or employees, arising from damage to any vehicle, personal injury, or monetary loss of any kind whatsoever. Drivers, pit crewmembers, and sponsors waive any claim they may have against a promoter, track operator, or ROAR, when they participate in any racing activity conducted under these rules.
- 1.4.3 The specifications and standards contained in these rules are intended as a guide with respect to safety and for the equitable conduct of races, and for no other purpose, either expressed or implied. The use of these rules by any association, organization, manufacturer or individual is entirely voluntary and ROAR will accept no responsibility for consequences resulting from their application.
- 1.4.4 No implied or expressed warranty of safety shall result from the publication of, or compliance with these rules. They are intended as guidelines for the conduct of the sport and are in no way a guarantee against injury of any sort to participants, spectators or others.
- 1.4.5 ROAR accepts no responsibility whatsoever for the failure or malfunction of any product built according to these rules, nor for the consequences of such failure or malfunction. Similarly, ROAR accepts no responsibility whatsoever for the failure or malfunction of any item of equipment used at a ROAR-sanctioned event, nor for the consequences of such failure or malfunction.
- 1.4.6 ROAR is not liable for the actions or decisions of any individual, race promoter or organization using these rules.

## **1.5 ENVIRONMENT, HEALTH AND SAFETY**

- 1.5.1 **Tobacco products:** All ROAR tracks and clubs should provide adequate smoking and chewing facilities to separate (or at least place down wind) the use of tobacco products from those with children or those wishing not to be confronted by tobacco smoke and wastes. Since laws vary across North America, this rule remains a recommendation. ROAR cannot make something illegal that lies outside of our jurisdiction. Otherwise, ROAR would outlaw the use of tobacco products at all ROAR events.
- 1.5.2 Open flames or smoking are prohibited within 50 feet of areas where fuel (either nitro or gasoline) is present.
- 1.5.3 Racing activities must always provide for the maximum safety of all individuals including spectators, drivers, pit crews, and officials. Care should be taken when organizing unusual or unfamiliar racing formats or events, to ensure that safety is not compromised.
- 1.5.4 The safety of spectators is of prime importance and must be considered when laying out tracks and spectator areas. A positive means of stopping a vehicle must be provided between the track area and any area accessible to spectators, drivers, officials, or pit crews. The main consideration for selecting this barrier will be the protection of the individual and not protection of the cars or convenience of operation. Barriers must meet the specifications contained in section 2.1: Track Barriers
- 1.5.5 The safety of officials, drivers, and pit crews is of equal importance, but it is assumed that they are more aware of any potential danger. Barriers as specified in section 2.1: Track Barriers shall be provided between the racing surface and the areas used for the pits and the drivers' stand, and to protect those officials who must occupy relatively fixed positions near the racing surface.

- 1.5.6 Everyone in the racing area and pits, including spectators, must wear closed-toe shoes. Anyone behind the spectator control barrier is not included in this requirement, provided there is a positive means of preventing entry to the racing area.
- 1.5.7 Disabled cars will be taken off the track. No repair work will be allowed on the track or the infield while a race is taking place.
- 1.5.8 A driver may not operate a vehicle while positioned outside the designated driving area or drivers' stand, nor may the vehicle be operated on any surface other than the racing surface or designated pit lane (where relevant).
- 1.5.9 The Race Director must ensure that all drivers, pit crewmembers, and spectators are in a safe position while the cars are on the track.
- 1.5.10 Prior to operating a vehicle, all drivers must sign in and give officials the radio frequencies that will be used. Except in the case of a driver using a 2.4GHz DSS system, Race officials must approve any changes to these frequencies.
- 1.5.11 Rule deleted, repeat of 1.5.10
- 1.5.12 All drivers operating vehicles in practice sessions, or working on a vehicle in the pits with its radio on, must comply with the appropriate frequency control system in use at the facility, or have approval from a race official. (See Rule 2.3.3 for exceptions). At facilities using the "clip off" system, the driver must display the frequency clip prominently, preferably on the antenna of the transmitter. At facilities using the "clip on" system, the driver must ensure that a clip or other marker displaying his name is attached to the correct frequency identifier on the frequency board before turning on his transmitter.
- 1.5.13 Drivers must turn their radios on before turning their vehicle on or starting its engine. Drivers must also turn their vehicle off or stop its engine before turning their radios off. All fuel-powered cars on the track or in the pits must be controlled by a working radio, be on a test stand, or be in the hot pit area.
- 1.5.14 Race Officials may inspect any component of a vehicle at any time if a safety hazard is suspected.
- 1.5.15 Off-road cars with exposed gears must be equipped with gear covers. Vehicles found without gear covers at pre-race inspection will not be allowed to compete in that race, and vehicles found without gear covers at post-race inspection will be disqualified from that race unless adequate proof can be provided that the cover was forcibly lost during the race.
- 1.5.16 At all ROAR events, functioning portable UL approved 2-1/2 pound minimum, ABC rated dry chemical or halon fire extinguishers, equipped with capacity gauges, must be in the pits and at trackside.
- 1.5.17 At fuel events, provisions for the proper disposal of waste fuel must also be in place.
- 1.5.18 A suitable, weatherproof first aid kit, composed of individually packaged supplies, must be available at all events, and a telephone number for medical assistance should be posted on the first aid kit, at the Race Control area, and near all phones.
- 1.5.19 For safety reasons, if an auxiliary battery is used in any vehicle to provide power to the radio system, this battery should not have a higher voltage than the voltage listed in the manufacturer's specifications for the radio receiver or servos being used.

1.5.20 The use of flammable liquids for the purpose of cooling overheated engines is strictly prohibited. At least two half-gallon containers of water must be available in the pits for cooling overheated engines.

## 1.6 OFFICIALS

1.6.1 ROAR wants to assure the fair application of these rules at Roar-sanctioned races of all levels. The number of officials required to conduct an event depends on the event level. As the number of entries at, or the importance of the outcome of an event, increases, so does the need to increase the number of officials to handle the required duties. The Race Director needs to have extensive staff coordination and delegation experience to successfully manage a ROAR Level 4 or 5 event.

1.6.2 Level 1 races have the minimum requirements for officials, needing only a Race Director, Technical Inspector and Scorekeeper. The list of officials below provides guidance as to the duties to be handled at the different levels. Having quality, knowledgeable personnel and the racer's respect of the host's ability to apply ROAR rules is paramount in having an event go well. When all participants (racers, officials, organizers, etc.) are aware of their position and corresponding responsibilities, the event will go smoothly.

1.6.3 Refreshments and necessary relief time should be provided for any officials who, because of their race duties, may have difficulty getting time for these necessities on their own. Complimenting members of your work force with refreshments is highly appreciated.

1.6.4 Any rule listing an Official indicates the lowest ranking Official given authority by ROAR to take action on the rule. This does not limit or restrict a higher ROAR Official from imposing a similar, overriding, or more immediate action.

### 1.6.5 Requirements for Officials

OFFICIAL NAME	Event level	ROAR Membership
Designated ROAR Official	3,4,5	Full
Race Director	1,2,3	Full
	5	Full for minimum 1 year in the past 3 years
Referee	3 Suggested	Full
	5 Mandatory	Full for minimum 1 year in the past 3 years
Finish Line Judge	5	Full
Technical Inspectors	All	Full
Scorekeepers	All	Full
Registration Controller	2,3,4,5	Full
Radio Impound Deputies	3,4,5	Full or single-event
Track maintenance (non-official)	All	Full or single-event
Snack Sales (non-official)	All	None
Sanitary & facility maintenance (non-official)	All	None
Crowd Control (non-official)	3,4,5	None
Announcers (other than the Officials named above)	2,3,4,5	None



- 1.6.6** Authorities and responsibilities:
- 1.6.6.1 The Race Director and Referee are responsible for making immediate official judgments and/or applying penalties according to the ROAR rules through the course of an event.
  - 1.6.6.2 In the event of disagreements among Officials, the final decision lies with the Official highest on the chain of command (listed in 1.6.11) who witnessed the incident.
  - 1.6.6.3 The Designated ROAR Official, Race Director, and Referee may not hold any other duties. Other Officials may assume more than one duty if necessary, although one Official per duty is ideal. For Levels 3-4 events these officials may race or participate but only if they have an announced co-official who will assume those duties when the participation takes place.
  - 1.6.6.4 The National ROAR Official, Race Director, and Referee cannot race or participate as a pit person in the hot pit area in Level 5 events at which they are officiating. The NRO, Race Director, and the Referee will be acknowledged at the first drivers' meeting. If these officials require relief from their duties a public announcement shall be made naming their replacement.
  - 1.6.6.5 The ROAR Officials at level 3-5 events represent ROAR and therefore have taken the responsibility to ensure that the ROAR rules are interpreted and applied correctly. This person is the Senior Official at the event.
  - 1.6.7 The Race Director, Designated ROAR Official, and/or Referee will have the authority to penalize or disqualify any driver for the violation of these rules, including any of the special rulings described in 1.2.7 and 1.2.8 above.
  - 1.6.8 The Race Director will have overall responsibility for the conduct of an event according to these rules.
  - 1.6.9 Race personnel will be directly responsible to the Race Director. The Race Director is responsible to the Designated ROAR Official during the event and ultimately to the ROAR Executive Committee.
  - 1.6.10 Any finding, penalty, or disqualification assessed at an event is final for that event, but will not imply or create a precedent for any other event unless specifically confirmed as such by the ROAR Executive Committee.
  - 1.6.11 For procedural and technical rulings and policies at an event, the chain of command and authority, from lowest to highest, is: (1) Race Official; (2) Race Director; (3) Designated ROAR Official.

## **2 TRACK SPECIFICATIONS**

### **2.1 BARRIERS**

- 2.1.1 Barriers must be supported in such a manner that sharp contact will not cause them to fall over or become ineffective, thus allowing cars to pass through an opening.
- 2.1.2 All barriers must be in good condition, not deteriorated by weather or other causes.
- 2.1.3 Permanent features of the race site, such as curbs or grassy areas, may be utilized.
- 2.1.4 Spectator control must be established at least five feet outside the barriers. For fuel on-road courses, control should be established at least ten feet outside the barriers. For 1/5-scale courses, control should be established at least 25 feet from high-speed areas of the track.

2.1.5 Minimum barrier specifications are as follows: (metal barriers may be substituted)

Class	Outer barriers			Inner Barriers		
	Thickness	Height	Material	Thickness	Height	Material
1/12 and 1/10 on-road Electric	0.5"	3.5"	Plywood	1.5"	3.5"	Wood
				2" diameter		PVC Pipe
1/10 off-road Electric and Fuel	0.5"	3.5"	Plywood	3" diameter		PVC Pipe
1/10 on-road Fuel	0.75"	7.5"	Plywood	1.5"	3.5"	Wood
1/8 off-road Fuel	0.75"	7.5"	Plywood	3" diameter		PVC Pipe
1/8 on-road Fuel	0.75"	7.5"	Plywood	1.5"	3.5"	Wood
1/5 on-road	0.75"	7.5"	Plywood	1.5"	3.5"	Wood
Electric oval	0.75"	11.875"	Plywood	1.5"	3.5"	Wood
Fuel Oval	0.75"	11.875"	Plywood	1.5"	3.5"	Wood

2.1.6 In addition to the barriers specified above, the following should be used to protect any spectator areas:

- On road courses, the spectator areas in high speed portions of the track should be separated by a catch fence. This should be wire fence or construction netting at least 24" high, placed 5' or more from the outer retaining wall.
- On 1/5-scale road courses, a three-foot high secondary barrier (catch fence), capable of retaining a vehicle at speed, must be placed in all areas where the cars are traveling in excess of 25mph. It must be positioned either behind the 10 inch outside barrier or placed at a minimum of 16 inches from the marking lines of the track if no other outside barrier is used. This barrier must be made of a material capable of stopping a 1/5-scale vehicle.

2.1.7 All barriers, portable or permanent, should be linked in such a manner that they present a surface toward the track that will not damage a vehicle if it makes contact in a grazing manner while proceeding around the track. Overlapping of barriers must always be away from the direction of travel.

2.1.8 A positive means of stopping a vehicle that leaves the racing surface must be provided.

2.1.9 Supplemental barriers sufficient to stop a vehicle must be placed in any area where swinging wide or loss of control could result in a vehicle going beyond the outer retaining barrier. Such barriers should be no closer than 18" to any portion of the racing surface.

2.1.10 The outer limits of the track must have barriers that will prevent cars from leaving the racing surface under normal racing conditions. These barriers must be easily distinguishable to the drivers.

2.1.11 Lanes must be sufficiently separated by either natural or artificial barriers to prevent cars from crossing into oncoming traffic. Where tracks have multiple layouts, those sections not in use must be separated from the racing configuration by barriers or other deterrents that prevent cars from using these sections.

2.1.12 Tapered boards, highway dots, or similar deterrents should be placed approximately 6" inside the inner-boundary turn markings to discourage corner cutting. Such devices may not be higher than 2" and must be tapered to allow cars to ride over them. They should be firmly secured to prevent movement onto the racing surface.

- 2.1.13 No device may be used on a high-speed portion of the track or at the end of a high speed straightaway that may cause a vehicle to be launched upward if struck. Plow discs or similar devices may not be used at the end of high-speed straights.

## 2.2 RACING FACILITIES

- 2.2.1 For fuel-powered racing, a pit lane must be provided that has a convenient and safe entrance and exit to and from the racing surface. It must be separated from the racing surface by a barrier of the same specifications as the inner barriers for the class of cars being raced. There must be a second barrier of at least the same specifications of the outer barrier between the pit lane and the working pit areas.
- 2.2.2 All refueling, repairing, or servicing of cars must be accomplished with the vehicle fully behind the barrier between the pit lane and the working pit area, and not in or over the pit lane. When pitting the car for fuel the fueling apparatus cannot be in the tank while over the pit lane. Unintentional waving of the fueling apparatus over the pit lane will not be penalized unless fuel is spilled in the pit lane and not immediately cleaned up. Off road cars may be placed on top of the exterior pit walls for servicing provided the wall has been designed so that the car is secure and stable.
- 2.2.3 A hot pit area, where fuel engines can be started and tested, should be provided that is separate from the racing pit area.
- 2.2.4 A drivers' area or stand must be provided that gives all drivers an essentially equal view of the track during practice and competition. Two and one-half feet (2.5') of space per driver is the recommended minimum. Elevated drivers' stands are recommended provided they are constructed in such a manner as to afford safety to all drivers standing on them. Flooring material will be secured and capable of holding all drivers. A railing or other safety device is recommended for any stand over 18" above the ground. If stairways are required, they must be constructed to meet local safety codes.
- 2.2.5 An area that is accessible to handicapped drivers must be provided which allows an unobstructed view of the track.

## 2.3 RADIO IMPOUND

- 2.3.1 Radio Impounds are required for all Level 3-5 events. It is suggested that lower level events establish a Radio Impound area if possible. All radio transmitters, including those operating on 2.4GHz DSS, must be impounded prior to the start of the first qualifier, and prior to start of racing on subsequent days. It is recommended that radios be disarmed by the driver at the time of impound and when returned after a race, by removing the battery pack, module, or crystal. Radios will be released at the end of the day's activities, or when a driver is leaving the race site. If release is prior to the end of the day's activities, the radio must be disarmed.

**Note: The impounding of modules only without the full transmitter is not allowed.**

- 2.3.2 The Race Director will provide:
- Protected and secured storage for impounded radios
  - Procedures to ensure that impounded radios are turned off
  - Procedures to ensure an orderly dispersal of radios for racing use
  - Procedures to ensure that no more than one radio on any one frequency is released from impound in any race.
- 2.3.3 Radios designed to operate servos without transmitting RF (usually by means of a direct connection between the transmitter and the receiver) may be used in the pits if approved by the Race Director. In such cases, all of the racer's modules or transmitter crystals for that radio system must be impounded.

**\*Note:** If drivers are allowed to impound their own radios, they should be reminded frequently to ensure that their radios are off and disarmed when impounded.

## 2.4 SURFACES

2.4.1 Water hazards of any type are strictly prohibited. Water hazards are defined as permanent features of the track that contain standing water. Puddles formed by rain or by the watering of an offroad track are not defined as hazards, although precautions should be taken to avoid damage being caused to cars by having to negotiate such puddles.

2.4.2 Surface (lane) widths for each class/scale are:

Scale/Class	Surface	Minimum lane width
1/12 Electric on-road – 4 cell	Carpet or paved	6 feet
1/12 Electric on-road – 6 cell	Carpet or paved	8 feet
1/12 Electric Oval	Carpet or paved	10 feet
1/10 Electric Oval	Carpet, dirt or paved	10 feet
1/10 Electric off-road	Off-road	8 feet
1/10 Electric on-road	Carpet	8 feet
1/10 Electric on-road	Paved	10 feet
1/10 Electric CART/F1/IRL	Carpet or Paved	8 feet
1/10 Fuel on-road	Paved	10 feet
1/10 Fuel off-road	Off-road	8 feet
1/8 Fuel on-road	Paved	12 feet
1/8 Fuel off-road	Off-road	10 feet
Monster Truck	Off-road	10 feet
1/5 Fuel on-road	Paved	15 feet

2.4.3 On-road paved track surfaces must be asphalt or finished concrete with smooth expansion joints. The race direction is clockwise for road courses and counter-clockwise for oval tracks. A change in race direction is permitted if notification is included in the race flyer.

2.4.4 Off-road courses may be kept damp or left dry. When qualifying, an Off-Road track's surface condition (damp or dry) must be maintained through the entire round as necessary to help provide equal conditions for each racer. Race direction is optional, but clockwise is recommended.

2.4.5 Dirt oval courses should be hard packed, whether damp or dry. Race direction will be counter-clockwise.

2.4.6 Off-road jumps should be designed so that they minimize damage to cars in the normal course of racing, do not pose a hazard to turn marshals, and do not interfere with timing and lap scoring. Special care should be taken when placing jumps close to the entry or exit from the pit lane to ensure that cars entering or exiting the pits are not damaged by cars negotiating the jumps.

## 3 DRIVER RULES

3.1.1 ROAR membership is required to participate in any ROAR-sanctioned event.

3.1.2 Only ROAR members having current full year memberships may participate in Level 4 and Level 5 ROAR National Championships, either as drivers or pit crewmembers. Drivers entering these events must present proof of current annual membership or join prior to participating.

3.1.3 Single event memberships may be offered at Level 1-3 events.

- 3.1.4 The Race Director of a Level 1-3 event has the right to refuse any entry application for a valid reason. The approval of the ROAR Executive Committee or the designated ROAR Official is needed for entry refusal of a ROAR member at Levels 4-5 sanctioned events. Drivers may withdraw from a class during an event but once withdrawn, cannot participate later as a driver in that class of that particular event.
- 3.1.5 All drivers must attend the drivers' meeting. Racing rules, approved deviations and event-specific rule interpretations or procedures will be covered during this meeting. Pertinent executive decisions and temporary necessary rule changes must be disclosed during Driver's Meetings. The Race Director may give a one-lap penalty on the best qualifier or best A main of drivers that do not attend or cause unnecessary delay of a drivers' meeting.
- 3.1.6 A driver will not permit another driver to compete for him in a race (heat or Final), and no non-driver will be allowed to operate a vehicle on the track during a ROAR-sanctioned event. A non-driver is any person not entered and registered as a driver for the event in question.
- 3.1.7 No person under suspension by the Executive Committee will be permitted to participate in any event hosted by an affiliated ROAR club or track or be allowed to enter the working pits or race areas of such events.
- 3.1.8 Drivers are responsible for the actions and conduct of their pit crew. Pit crewmembers must be, at the minimum, single event ROAR members if they are to be in the working pits, hot pits, or race area of levels 1-3 events and full members for all other sanctioned events.
- 3.1.9 During qualifying, one pit member per vehicle will be allowed in the hot pits. During the mains, two are allowed
- 3.1.10 The Radio Impound and timing/scoring areas are off limits to all participants unless otherwise directed.

## 4 RADIO EQUIPMENT

- 4.1.1 Radio control systems used in ROAR competition are limited to the following channels:
- **27 MHz:** Only frequencies 26.995, 27.045, 27.095, 27.145, 27.195, and 27.255 MHz
  - **75 MHz:** All Channels 61 through 90
  - **50 MHz:** Channels 00, 02, 06, and 08
  - **53 MHz:** Frequencies 53.100 through 53.800 MHz.
  - **2.4GHz DSS systems**
- 4.1.2 Drivers using 50 MHz and 53 MHz radios must have an FCC Amateur Radio license issued for that radio in their possession.
- 4.1.3 All radio equipment must conform to FCC rules. Only narrow band (20 MHz spacing) radios will be allowed to use the 75 MHz frequencies in ROAR competition. A frequency counter or similar device should be used to test for legal frequencies.
- 4.1.4 A driver must use his assigned frequency. Except in the case of 2.4GHz DSS systems, the Race Director must approve all frequency changes.
- 4.1.5 The use of radios operating on 29 MHz, 40 MHz, or CB (split) channels is prohibited.
- 4.1.6 Changing frequencies by interchanging transmitter and receiver crystals ("reversed frequencies") is prohibited.

- 4.1.7 Except in the case of 2.4GHz DSS systems, radios must display the clip for the frequency used during practice. These radios must be able to change transmitter frequency modules. At Level 3-5 events, two alternate frequency choices are required.
- 4.1.8 Transmitters are limited to the manufacturer's recommended voltage. External transmitter battery packs are not permitted.
- 4.1.9 Except in 1/5 scale and Monster Truck class vehicles, radio systems are limited to the use of two channels, operating two servos, or a combination of one servo and one electronic speed controller. More than one function is allowed per device, but a servo is limited to one output shaft. Control is limited to forward, brake, and steering. The use of reverse in competition is not allowed. On 1/5 scale vehicles, three channels and more than two servos may be used, but control is limited to forward, brake and steering.

## 5 COMPETITION RULES

### 5.1 GENERAL COMPETITION RULES

- 5.1.1 ROAR aims to promote family-oriented racing. Unruly or unsportsmanlike conduct will therefore not be tolerated. Individuals judged by the Designated ROAR Official or Race Director to be in violation of the spirit of this rule will be disqualified and requested to leave the race area.
- 5.1.2 For Level 3-5 sanctioned events, any deviation from ROAR rules must have been applied for in writing and approved by the ROAR Executive Committee (by signature of the Competition Director for Level 5 events or Sanctioning Director for Levels 3-4) in advance of the event, and must be prominent on entry forms and all advertisements. Deviations at Level 1 and 2 events must be prominent on all entry forms and advertisements but do not need written ROAR Executive Committee approval.
- 5.1.3 The race lengths specified for each class are mandatory for Level 3-5 events. At lower level races, race length is optional, but must be announced in advance.
- 5.1.4 Race lengths are:

Scale/Class	Race length: Qualifiers	Race length: A Mains	Race Length: Other Mains
1/12 Electric on-road	8 minutes	8 minutes (see Note)	8 minutes
1/12 Electric Oval	4 minutes	4 minutes	4 minutes
1/10 Electric Oval	4 minutes	4 minutes	4 minutes
1/10 Electric off-road	5 minutes	5 minutes (see Note)	5 minutes
1/10 Electric on-road	5 minutes	5 minutes (see Note)	5 minutes
1/10 Fuel On-road	5 minutes	45 - 60 minutes	15 – 30 minutes
1/10 Fuel Off-road	5 minutes	45 - 60 minutes	15 – 30 minutes
1/8 Fuel on-road	5 minutes	45 - 60 minutes	15 – 30 minutes
1/8 Fuel off-road	5-10 minutes	45 - 60 minutes	15 – 30 minutes
1/5 Fuel on-road	5 minutes	30 minutes	15 – 30 minutes
Monster Truck (Fuel)	5-10 minutes	30 - 45 minutes	15 – 30 minutes
Monster Truck (Elec)	5 minutes	5 minutes	5 minutes

NOTE: See Rule 12.3.7.3 for details of the triple A-Main system used for these classes.

## 5.2 GENERAL VEHICLE RULES

- 5.2.1 All vehicles entered for a ROAR-sanctioned event must comply with the dimensional requirements contained in this rulebook for the relevant class.
- 5.2.2 Vehicle batteries must be securely mounted. ROAR recommends limiting the radio receiver battery pack in all vehicles to 6 volts. This is usually accomplished by the use of five (5) NiCd/NiMh cells or four alkaline cells. Slightly higher voltages (Maximum 6 NiCd/NiMh cells) may be used for direct receiver power but this can result in an increased risk of receiver failure by over voltage. Receiver and servo power for electric vehicles may come from an electronic speed controller equipped with Battery Elimination Circuitry (BEC) or from a separate battery pack used for this purpose only. (See rule 1.5.18).
- 5.2.3 The use of traction control sensing devices, active suspension devices, and steering control devices aided by gyroscopes or accelerometers (G-force sensors) of any kind is strictly prohibited. Sensors may be used for the purpose of passive data recording but not for adjusting the performance of the vehicle while in motion.
- 5.2.4 No roll-over antennas are allowed unless noted in the class rules. Roll-over antennas are defined as any vertical antenna strong or stiff enough to support the weight of the vehicle when resting on the tip of the antenna and one side of the vehicle.
- 5.2.5 Multiple speed transmissions are not allowed unless noted in the class rules.
- 5.2.6 Any material used to add weight to a vehicle in order to comply with the minimum weight requirements for the class must be securely attached to the vehicle chassis. If such ballast falls off the vehicle during a race for any reason, and the vehicle is under weight at the post race technical inspection, the vehicle will be disqualified for that run. For all fuel classes, chassis weights must be securely mounted with solid mechanical fasteners such as bolts or screws.
- 5.2.7 No hazardous bumpers, nerf bars, chassis extensions, or other objects protruding from the vehicle are allowed.

## 5.3 CLASSES

### 5.3.1 Vehicle class definitions:

- 5.3.1.1 For the purpose of establishing specific rules, vehicles used in ROAR competition are divided into various classes according to the following criteria:
- Scale
  - Drive configuration
  - Type of power
  - Track surface and configuration
  - Body style
- 5.3.1.2 Scale Definition:
- 1/12 scale
  - 1/10 scale
  - 1/8 scale
  - 1/5 scale
- 5.3.1.3 Drive configurations definition:
- Two wheel drive (2WD), where power is transmitted to the rear wheels only, and
  - Four wheel drive (4WD), where power transmitted to all four wheels. Vehicles that are driven by the front wheels only are classified as four wheel drive.

- 5.3.1.4 Type of power: Vehicles may be powered by electric motors or by fuel engines. Electric motors are further classified as stock or modified. Fuel engines are classified primarily by fuel type, and then by engine displacement.
- 5.3.1.5 Track surface and configuration: Authorized surfaces include carpet, dirt, and pavement. Configurations include ovals and road courses. Surface and configuration can be combined in many ways to provide a variety of racing venues.
- 5.3.1.6 Body style: A wide variety of bodies are authorized for use in ROAR competition. These are covered in detail in the Body Rules section.
- 5.3.1.7 ROAR reserves the right to specify what classes of drive, power, and body style can be used on the various track surfaces and configurations.
- 5.3.1.8 Provisional or Demonstration classes are those being raced where the level of interest or participation does not warrant National Championship status. Rules may be provided for these classes, and they may be run at all levels, unless specifically prohibited. Cost controlled classes are authorized and encouraged. See Cost Control Rules.

#### 5.3.2 Driver categories:

- 5.3.2.1 Drivers may also be categorized according to various criteria. Juniors and Masters categories are encouraged, as well as Novice and Beginner's categories. Any driver category may be linked with any vehicle class. Drivers not qualifying for these categories compete in an open category.
- 5.3.2.2 When Juniors and Masters categories are run, the following rules will apply:
  - Juniors must be 15 years old or younger on the final day of the event
  - Masters must be at least 40 years old or 45 if on road fuel, on the first day of qualifying.
  - At Level 4-5 events, proof of age is required for entry in the Juniors or Masters categories. Proof of age for Juniors is provided by means of a Birth Certificate, and for Masters by means of a government-issued ID or Driver's License.
  - At Level 5 events, Juniors and Masters may enter other classes in the open category, but not in the same vehicle type.
- 5.3.2.3 When Novice or Beginner categories are run, the following rules will apply:
  - The definitions used to determine Beginner and Novice must be clearly stated on the event entry form or otherwise publicized before the event.
  - Beginner and Novice categories may be offered at events up to and including level 3 only.
  - Drivers entered in a novice or beginner category may not enter other classes in other categories, but may enter multiple classes within their category, if available.

## 5.4 TECHNICAL INSPECTION

- 5.4.1 Each vehicle should satisfactorily pass a pre-event technical inspection before being allowed to compete.
- 5.4.2 All rules must be strictly adhered to. No vehicle will be allowed to race until it has been cleared to do so by the Technical Director. Any violation must be corrected before the vehicle is raced.
- 5.4.3 All vehicles must pass technical inspection prior to or after every race, or both. For A Mains both pre and post race inspections are required. Any vehicle found to be illegal during a **pre**-race inspection will not be allowed to race in that condition. Vehicles found to be illegal during a **post**-race inspection will be disqualified from that race.



- 5.4.4 Technical inspections include but are not limited to checking the vehicles height, length, width, and minimum weight (with personal or handout transponder installed). No parts of the car other than the spur gear and tires may be at less than the minimum ground clearance for a specific class.
- 5.4.5 Except in the case of 2.4GHz DSS systems, the technical inspectors will ensure that the driver's radio is on the proper frequency.
- 5.4.6 During width measurements, vehicles must roll freely in the tech box at ride height. This will be verified by lifting the rear of the box to 45 degrees above horizontal, and the car must roll forward under its own weight.
- 5.4.7 All dimensions or other specifications quoted as "maximum" include all manufacturing or other tolerances. No further tolerance is allowed above any maximum specification.
- 5.4.8 Bodies must remain as originally approved. Flaring front fenders or making any other aerodynamic modification is not permitted.
- 5.4.9 The minimum vehicle weights listed in the Class specifications include transponders. No distinction is made between personal and "handout" transponders. For all fuel classes vehicle weights are measured without fuel in the tanks.
- 5.4.10 All vehicles must have the correct numbers as described in rule 5.6.4.
- 5.4.11 The Designated ROAR Official, Technical Inspectors, and the Race Director have the right to subject any vehicle to mechanical or visual inspection or impound at any time. It is the driver's responsibility to tear down a vehicle for inspection if required to do so.
- 5.4.12 The Race Director has the right to limit admission to any area used for tech inspections
- 5.4.13 During post race inspection, the effects of normal wear and race distortion or damage should be taken into consideration. For post-race inspections, a "cooling-off" period of no more than 10 minutes may be allowed to eliminate any temperature effects on sizes, capacities, etc.
- 5.4.14 **Handout Motor rules:**
  - 5.4.14.1 Drivers may not use their own stock motors or stock motor components when the event requires handouts.
  - 5.4.14.2 Either rebuildable or non-rebuildable stock motors may be selected as handouts, but not both at the same event. Regardless of which handout is selected, only one model from one manufacturer or distributor may be used at any one event.
  - 5.4.14.3 Handout motors and components (where applicable) will be permanently marked with a number that identifies the driver. Motors may not be swapped between drivers.
  - 5.4.14.4 It is the Race Organizer's responsibility to ensure the proper marking of the motors. If the Race Organizer is not willing to put in the extra effort to mark Rebuildable stock motor components as described, then non-rebuildable stock motors should be used as handouts.
  - 5.4.14.5 If Rebuildable stock motors are used, the term "handout motor" includes these components: cans, endbells, brush hoods, bushings and armatures.
  - 5.4.14.6 When a Rebuildable stock motor is used as the handout at a ROAR Level 4 event, armatures may not be swapped between cans, and the armature must always have the same number as the can.
  - 5.4.14.7 When non-rebuildable stock motors are used as handouts, the motor should be sealed with epoxy or similar material, such as SCCA tech tape, that would chip, rip or come off if the can and endbell were separated.
  - 5.4.14.8 Bushings may not be cut or modified in any type of stock motor.

## 5.5 TURN MARSHALING

### 5.5.5 Responsibilities

- 5.5.5.1 Drivers must marshal for their designated race.
- 5.5.5.2 Qualified ROAR members may substitute with the approval of the Race Director. It is the original driver's responsibility to find a substitute and he is responsible for the actions of that substitute.
- 5.5.5.3 Drivers who bump up are not required to marshal if their previous main contained at least 12 drivers.
- 5.5.6 Turn marshals are not permitted to repair vehicles. Marshals will take disabled vehicles to the closest outer edge of the racetrack as soon as possible.
- 5.5.7 A vehicle running on the track has the right-of-way over a vehicle that has gone off the track, turned over, or otherwise had problems.
- 5.5.8 When marshaling a vehicle, it should be returned to the point where it left the racing surface. Care must be exercised not to interfere with on-coming vehicles.
- 5.5.9 Only the designated marshals are permitted to handle vehicles on the racetrack during a race. No one else may enter the racetrack to repair or retrieve a vehicle.
- 5.5.10 Marshals for 1/5 scale classes can be a pit crew member. No one, marshals or otherwise may enter the race track area until a Yellow Flag condition is called and all vehicles have slowed to a controlled pace.

## 5.6 SCORING

- 5.6.1 For Level 2, 3, and 4 events, a computer scoring program is required that is capable of recording and sorting driver and class information, setting up qualifying heats, creating standings from qualifiers according to the Qualifying system specified for the event, setting up the main events, and running all the races. The program must be capable of receiving and processing information from existing transponder systems. At Level 5 events, this program must be pre-approved by the ROAR Executive Committee.
- 5.6.2 When personal transponders are used, these must be fastened to the vehicle in a permanent manner. All host-provided ("public") transponders must be mounted in a position that will ensure reliable reception by the computer system. The race director can direct the placement of transponders, and can require a change of position in the event of bad reception. If a transponder is not installed, is lost, or falls out during a race, the driver will not be scored in that race. The driver is responsible for ensuring that the correct transponder is fitted to the vehicle, or that the correct personal transponder number has been provided for the scoring program. If duplicate transponder numbers are received at registration then the original AMB transponder number has priority over the duplicate. Placing a transponder in a location that may damage the transponder is prohibited. Final results will be based on the transponder counts.
- 5.6.3 The timing loop/bridge (finish line) should be located where reliable hits will be obtained, and where it is unlikely that a vehicle can miss being counted. For fuel main events the loop should be located within a quarter lap prior to the entrance of the refueling pits. If a vehicle does miss the loop due to a racing incident that is witnessed by a race official, obvious on the race print out, or is verified on a videotape, the driver will get credit for the lap. No driver involved in a racing incident whose lap is not counted as a result of the incident will be required to reenter the racing surface at sharp angle or reverse direction in order to be counted.

- 5.6.4 All vehicles must carry three identifying numbers positioned so that at least one number can be seen from the right, left, and front of the vehicle. Exception: 1/12 cars only require one number on the front. Numbers must be black numerals on a white background. Minimum number size is 1.5" high with .25" stroke. Numbers may not be trimmed to eliminate the white background. The Race Director has the right to require a specific location for vehicle numbers. At a Level 3-5 event the Race Director may disqualify a driver whose vehicle has illegal, wrongly placed or missing numbers.
- 5.6.5 Race durations, not including the final lap, are specified in rule 5.1.4 above. Regardless of the length of the race, at the completion of the time, the end of the race will be announced via PA system, horn, or other audio method. All drivers must then complete the lap they are running. The driver will be credited with the time and lap of the final lap. In cases where two drivers have the same number of laps in the same round, the driver with the lower elapsed time will be positioned higher in the racing order.

## **5.7 QUALIFYING RULES**

- 5.7.1 A driver's official time will be the total laps completed by his vehicle and the total time elapsed from the starting time, as determined by the method of qualifying, until the vehicle crosses the finish line on the final lap. If the final lap is not completed, the driver will be credited with the number of full laps finished and the time for those laps. A driver who completes 20 laps in 3:50.00 beats a driver with 20 laps in 4:02.00 in the same round.
- 5.7.2 When IFMAR qualifying is used, each vehicle is running against its own clock, and not against the other vehicles. Vehicles will be started individually, or rows of two or three if lap times are short. The interval between vehicles or rows must be such that all vehicles cross the starting line before the first vehicle crosses for the second time. At the conclusion of the designated race time, drivers will be instructed to continue racing until their name or number is called.
- 5.7.3 Qualifying positions for any one round will be determined based on laps and time.
- 5.7.4 Qualifying positions for main events at all Level 1-4 events and at Level 5 events for electric carpet, oval, and 1/5 scale will be determined by using the driver's single fastest qualifying heat, in descending order, until the field is completed, unless otherwise specified by the Race Director or by the ROAR Executive Committee.
- 5.7.5 At level 5 events for all classes except electric carpet, oval, and 1/5 scale, qualifying positions will be determined using the ROAR Qualifying Points system described in Rule 12.3.6.
- 5.7.6 The winner of each class will be the driver in the A main who finishes with the most laps in the least elapsed time, and whose vehicle is found to be legal on post race inspection. A triple A main system will be used at electric Level 5 events and may be used at lower level races. A driver who wins the first two A mains must sit out the final main. Refer to Rule 12.3.7.3 for description of the triple A-Main procedure.
- 5.7.7 Vehicles may not be pushed across the finish line. Vehicles must cross the line under their own power. Non-operating vehicles will be removed from the track. In fuel classes cars are not allowed to be restarted once the master clock has expired.
- 5.7.8 For purposes of qualifying and racing, the driver is scored, and not the vehicle. A driver must race the vehicle that he/she presents for technical inspection. Unless supplemented by event rules, a driver or a vehicle may not be changed during a qualifying run or during a main event. Qualifiers and Mains are deemed to start with the starting signal or green flag.

- 5.7.9 Unless otherwise specified in the Nationals Guidelines, the standard format for Level 5 events, except fuel on-road, is four qualifying rounds. Fuel on-road will run four to six rounds of qualifying. At Levels 3-4 events, a minimum of three qualifying rounds is required. For all other ROAR sanctioned races a minimum of two qualifying rounds is required. All of the above is dependant on favorable weather conditions.

## **5.8 STARTING – Electric Races**

- 5.8.1 The purpose of a starting procedure is to give each vehicle a fair start from its assigned grid position. Two methods are authorized for electric racing. These are the full-field start and the IFMAR, or staggered start. All mains will use a full-field start. Qualifying heats may use either method.
- 5.8.2 The starting grid should be on the longest straightaway and/or far enough from the first corner to allow vehicles to be under control before reaching it. The grid should be in a staggered pattern with 2 or 3 vehicles per row, and 3 to 4.5 feet between vehicles from front to rear.
- 5.8.3 For full-field starts, all vehicles should start on the computer tone or other signal given by the Race Director or Starter.
- 5.8.4 For IFMAR starts, vehicles are started at 1 to 3 second intervals as vehicle numbers are announced. On tracks with short lap times, vehicles should be started by rows at 1-second intervals. On tracks with longer lap times, vehicles may be started from a single line on the track. This line should be far enough from the timing loop to allow vehicles to reach normal speed.
- 5.8.5 A grace period before the start of a race may be allowed at the discretion of the Race Director but this must be announced at the drivers' meeting before racing begins. Only one grace period per race is allowed and it may not exceed two minutes.

## **5.9 STARTING – Nitro Fuel Races**

- 5.9.1 For qualifying races, it is recommended that IFMAR starts be used, with the vehicles starting at one to two second intervals from a staging area such as the pit lane. If rolling IFMAR starts are used then the vehicles may fuel and proceed towards the loop anytime once the timing loop is announced as 'hot'.
- 5.9.2 For main events and full field start qualifiers, a Le Mans-type start is recommended. For main events the vehicles should be lined up diagonally, at least ten (10) feet apart, on the longest straight by qualifying time, fastest qualifier at the front. For Le Mans starts, vehicle mechanics must be clear of the racing surface to prevent injury and all drivers must have clear visibility of their vehicles.
- 5.9.3 Vehicles will be called to the track three minutes prior to the start of a race. They will be given a minimum of 2-1/2 minutes for warm up and practice. Thirty seconds before the start, they will be called to the starting line for refueling, final preparation, and lineup. At the three-second mark, the flag will be touched to the ground and all mechanics will place their vehicles on the ground and release them. Within the next three seconds, and after all vehicles are released, a tone or lifting the flag will start the race.

- 5.9.4 The Race Director will make every effort not to delay the start of a race. Vehicles will not be allowed on the track before the three (3) minute warm up period. After the three-minute period is announced, the start will be as close to three minutes as possible.
- 5.9.5 A grace period during the warm-up before the start of the A-Main event may be allowed at the discretion of the Race Director but this must be announced at the drivers' meeting before racing begins. Only one grace period is allowed and it may not exceed two minutes.

## **5.10 FREQUENCY CONFLICTS**

- 5.10.1 In cases of frequency conflict, the higher qualified driver will have first choice of frequency. Second highest qualifying driver will have second choice of frequency, etc. For example, driver A is on Freq #2 and is qualified for the A main. Driver B is also on Freq #2 and is also qualified for the A main. Driver A is qualified first, and as such, would get first choice of frequency. Driver A can elect to retain Freq #2, in which case driver B would have to change; or he can choose any other legal frequency, which could cause another driver to change. The Race Director may require driver A to retain Freq #2 if an unsportsmanlike act is judged to be transpiring.
- 5.10.2 If there are seven drivers on 27 MHz in a main event, the slowest driver will have to change to an approved channel in the 75mhz range. If the slowest driver cannot or will not change to an open, approved 75mhz channel, the driver will be disqualified. (Courtesy and fair play should be called for by the Race Director to see if another driver in the main can change frequency if the slowest driver cannot change to a 75 MHz channel.)

## **5.11 EVENT ELIGIBILITY**

- 5.11.1 Except as provided herein and below, any ROAR member is eligible to enter any ROAR-sanctioned event.
- 5.11.2 Drivers who are currently qualified for, or have participated in two of the previous IFMAR World Championships are not eligible to enter stock classes at Level 3-5 events. Other restrictions may be imposed on entering the Stock and Modified Off-road Nationals.
- 5.11.3 To be eligible to enter a specific class or classes at a Level 3-5 event, a driver may be required to meet qualifying and pre-entry requirements established by the ROAR Executive Committee.
- 5.11.4 Regional Championships may be entered by any driver from the host region or adjacent regions which share the same border. Drivers are allowed only one Regional Championship title per class per scale per calendar year. A title-winning driver may only enter a different class or scale at subsequent Regional Championships for the remainder of the calendar year.
- 5.11.5 Members who are not US or Canadian citizens wishing to compete in National Championships must (present permanent resident visas) have been resident in the USA or Canada for at least 12 months prior to the event. Proof of residency may be required. In the case of a member too young to be issued a driver's license, this proof must be based on the driver's license or identity document of the member's legal guardian.

## **5.12 BLACK FLAG**

- 5.12.1 A black flag will be given to a driver whose driving, vehicle operation, or performance constitutes a hazard to the other vehicles in the race. This includes insufficient skills to compete in the class, unsportsmanlike driving, and intentional hitting of other vehicles, intentional short coursing, intentional corner cutting, intentional blocking when being overtaken, illegal or improper vehicle numbers and other such acts.
- 5.12.2 When a driver is given the Black Flag, it means that driver must pull his/her vehicle off the track immediately. The driver will remain on the drivers stand until that heat or race is over.
- 5.12.3 A black flag ruling may be used at any time for unsportsmanlike conduct or abusive language to other drivers or race officials.
- 5.12.4 A driver who receives three warnings in an event from a referee or race official will be black-flagged.
- 5.12.5 Any vehicle that loses its body or that cannot be controlled properly due to radio problems, race damage, or missing parts will be black-flagged.

### 5.13 DISQUALIFICATION

- 5.13.1 Failure to comply with any of these rules, not limited to items covered in this section, may result in disqualification by the Race Director. Disqualification may be for a single class or for the entire event.
- 5.13.2 Disqualification means that the driver will not be allowed to race or continue racing. Any driver who is disqualified for the entire event may be required to leave the racing facility. There will be no refund of entry fees to a disqualified driver.
- 5.13.3 Any of the following actions on the part of a driver or member of his crew **will** result in mandatory disqualification from an event:
  - 5.13.3.1 Not having a current ROAR membership, failing to complete or sign required registration forms, or submitting an application, registration, or other ROAR form with a falsified signature.
  - 5.13.3.2 Using other than an authorized FCC frequency.
  - 5.13.3.3 Not taking a vehicle or radio to the inspection area when directed to do so.
  - 5.13.3.4 Operating a vehicle near the track that could endanger others in the area.
  - 5.13.3.5 Drinking intoxicating beverages, using illegal substances, or showing evidence of being under the influence of an intoxicating beverage or illegal substance in the pits or the race area.
  - 5.13.3.6 Taking part in a protest demonstration in the pits, on the track, or in the surrounding area before, during, or after a race.
  - 5.13.3.7 Entering restricted areas or event scoring areas without proper authorization.
  - 5.13.3.8 Assaulting another individual. This will also result in suspension of ROAR membership for a minimum of 90 days.
  - 5.13.3.9 Turning on a radio during a race to affect another driver's vehicle.
- 5.13.4 The following offenses by a driver or member of his crew **may** result in disqualification if deemed appropriate by the Race Director. If not deemed appropriate, the minimum penalty will be no score for the race in question. A second offense of the same type may result in immediate disqualification:
  - 5.13.4.1 Using an engine, motor, or part that does not comply with the rules.
  - 5.13.4.2 Subjecting a Race Official to improper language or other demeaning actions.
  - 5.13.4.3 Having a transmitter in the race or pit area without permission, on a second offense (see rule 5.14.10 for first offenses). **Note:** This includes 2.4GHz DSS systems.

- 5.13.4.4 Except in the case of 2.4GHz DSS systems, using other than an assigned frequency.
  - 5.13.4.5 Allowing another individual to substitute for them in a race. In this case, both drivers may be subjected to disqualification.
  - 5.13.4.6 Ignoring a black flag.
  - 5.13.4.7 Deliberate abusive nerfing, bumping, or blocking.
  - 5.13.4.8 Not submitting his vehicle for technical inspection prior to racing (when pre-race inspection is in force).
  - 5.13.4.9 Loss of ballast used to make the vehicle meet legal weight. (See rule 5.2.6)
  - 5.13.4.10 Use of illegal or banned tire-cleaning or traction chemicals or compounds.
  - 5.13.4.11 Use of an illegal, unmarked or otherwise improper tire when the 'Handout tire' rules are in force.
- 5.13.5 Infractions must be witnessed by a Race Official and brought to the attention of the driver before a penalty or sanction is assessed. Track infractions will be announced during the race. However, it is the responsibility of the driver to observe track rules even if the infraction is not announced at the exact time it took place.
- 5.13.6 A disqualified or penalized driver may protest the decision of the Race Director to the highest-ranking ROAR Official assigned to the event. The decision of the highest-ranking ROAR Official will be final. Such protest must follow the protest procedure outlined in 5.15 below.

## 5.14 PENALTIES

- 5.14.1 Failure to comply with any ROAR rules, not limited to those items covered in this section, may result in a penalty being assessed by the Race Director.
- 5.14.2 Time penalties will be added to the time recorded for the race in which the penalty is incurred.
- 5.14.3 Lap penalties will be subtracted from the total laps recorded for the race in which the penalty was incurred.
- 5.14.4 The Race Director may assess "stop and go" penalties, with or without delay, instead of time penalties. During a "stop and go" penalty, the vehicle must be stopped in the pit lane or other designated area, and lifted high enough for another vehicle to pass underneath it.
- 5.14.5 **Jumped starts:**
- 5.14.5.1 **Definition:** A jumped start is any movement of a vehicle between the time the Starter announces the start time and the starting signal.
- 5.14.5.2 **Penalties:**
- **For Electric classes:** If one or more vehicles jump start, a false start will be declared, and the grid will be re-formed. If the same vehicle moves a second time, it will be moved back the length of the grid from its original starting position.
  - **For fuel classes:** A ten second penalty will be assessed for a jumped start in a qualifier using a gridded stationary start, and a one lap penalty will be assessed for a jump start in a main race. Neither type of race will be re-started for a jumped start. For IFMAR qualifying starts, when a driver starts out of turn, a stop and go penalty may be assessed if the driver does not pull over and allow the other vehicles to pass before continuing.
  - **For any class:** If a jumped start is not called by the officials immediately at the start of a race but can be verified afterwards by at least two race officials using any recording device, a ten second penalty will be added to that offenders' particular qualifying time or if a main event , a one lap penalty will be assessed.

#### 5.14.6 Corner cutting or short-coursing:

- 5.14.6.1 **Definition:** Corner cutting or short-coursing is any deliberate or accidental maneuver that shortens the length of the course for a vehicle traveling around the track.
- 5.14.6.2 **Penalty:** For each incident, cutting a marked corner will incur a ten second penalty and short-coursing will incur a one lap penalty. (See penalty chart at end of this section.)
- 5.14.6.3 If the driver stops his vehicle in the area of the corner cutting infraction and allows the vehicle that was immediately behind him when the corner was cut to pass, no penalty is applicable. If a short-coursing vehicle is returned to the point where the infraction took place, no penalty is applicable.

#### 5.14.7 Improper re-entry to the racing surface:

- 5.14.7.1 **Definition:** Improper re-entry is any maneuver that adversely affects the ability of other drivers in the race to safely operate their vehicles in the vicinity of the vehicle re-entering the racing surface, whether from the pit lane or any other point.
- 5.14.7.2 **Penalty:** A ten second penalty in that qualifier or main
- 5.14.8 Refueling, repairing, or servicing a vehicle in the pit lane or on the racing surface (see rule 2.2.2) a “stop and go” penalty is assessed.
- 5.14.9 Driving in the opposite direction to the racing direction while on the racing surface: A one-lap penalty in that qualifier or main. **NOTE:** This rule applies to normal racing laps, to any driving prior to the start of any race and to any driving for the purpose of re-negotiating a cut corner or correcting a short-coursing infringement.
- 5.14.10 Operating a radio in the pits without the permissions specified in Rule 2.3: A minimum of a one lap penalty from the best qualifier or the main may be assessed at Race Director’s discretion in a Level 1 or 2 events. At Level 3-5 events, this penalty will be assessed for a first offense and the provisions or rule 5.13.4.3 will apply for a second offense. **Note:** This includes 2.4GHz DSS systems.
- 5.14.11 Failure to turn marshal: A one-lap penalty from the best qualifier or the main.
- 5.14.12 Failure by a driver to maintain a closed throttle or zero speed setting while his vehicle is in the hands of a marshal: A ten second penalty in that qualifier or main.
- 5.14.13 Repairing a vehicle while marshaling: For Level 3-5 events: A ten second penalty in the marshal’s previous qualifier or main.
- 5.14.14 Failing to respond in a timely way to an Official directive: One lap penalty subtracted from the best qualifier or main.

Action	During Qualifier	During Main
Improper re-entry to racing surface	10 second penalty	10 second penalty
Corner Cutting	10 second penalty	10 second penalty
Short Coursing	1 lap penalty for each incident	1 lap penalty for each incident
Refueling in pit lane or on the racing surface	Stop and go penalty	Stop and go penalty
Driving in opposite direction on track	1 lap penalty	1 lap penalty
Failure to turn marshal	1 lap penalty from best qual	1 lap penalty from best main
Failure to reduce throttle while in hands of a turn marshal	10 second penalty	10 second penalty
Repairing a car while turn marshalling	10 second penalty	10 second penalty
Failing to respond to a Race Officials request	1 lap penalty from best qualifier	1 lap penalty from best main



## 5.15 PROTESTS

- 5.15.1 Protests may be submitted against:
- Vehicles or parts of vehicles
  - Technical issues
  - Results
  - Race procedures, policies or decisions.
- 5.15.2 Protests considered by the Race Director to be frivolous or unsportsmanlike will not be accepted.
- 5.15.3 Protests may only be submitted by drivers properly entered in the event which is the subject of the submitted protest.
- 5.15.4 All protests must be submitted to the Race Director in writing. A sample protest form may be found in Appendix C.
- 5.15.5 Protests must be delivered to the Race Director within fifteen minutes of the posting of results of the protested qualifying round or main.
- 5.15.6 Protests must be accompanied by a \$20 fee per item protested, plus the retail replacement cost for each item protested if a tear-down is requested or required to evaluate the protest.
- 5.15.7 Vehicle or technical protests involving the qualifying heats of an event may only be submitted by drivers in the same vehicle class being protested.
- 5.15.8 Vehicle or technical protests involving a particular Main event may only be submitted by drivers in the same Main.
- 5.15.9 Any engine or motor that is protested may only be torn down for internal inspection at the end of the event. The engine or motor will be marked at the time of protest in such a manner that it can be identified at the end of the event.
- 5.15.10 A driver who has a protest lodged against his vehicle, or any part thereof, is required to make the vehicle available for inspection. Failure to do so will result in disqualification.
- 5.15.11 Vehicle or Technical protests:
- 5.15.11.1 The driver lodging the protest must deliver the written protest and protest fees to the Race Director prior to the initiation of the inspection of the protested vehicle. Those allowed to attend the inspection will be as follows (where relevant):
- The protester
  - The protested driver
  - The protested driver's mechanic
  - The Technical Inspector
  - The Race Director
  - The Designated ROAR Official
- 5.15.11.2 Designated representatives may replace any of the above.
- 5.15.11.3 The driver or mechanic may be required to dismantle the vehicle under the supervision of the Race Officials.
- 5.15.11.4 If the protested vehicle or part is found to comply with the sections of the rules for which it was protested, the protest fees including the item's retail replacement cost (if the item was destroyed by the examination) will be given to the protested driver.
- 5.15.11.5 If the protested vehicle or item is found not to comply with the sections of the rules for which it was protested, the protest fees will be returned to the protesting driver, and the protested driver disqualified.

#### 5.15.12 Organizational protests:

5.15.12.1 Only ROAR members taking part in the event may make this type of protest.

5.15.12.2 They must personally deliver a written protest along with a \$20 protest fee to the Race Director.

5.15.12.3 The protest must be filed within 15 minutes of the associated development that defines the results, procedures or policies being protested.

5.15.12.4 The protest must explain the problem and have a solution. If ROAR rules are referred to in the arguments, they must be quoted or referred to by rule number.

5.15.12.5 If the Race Director determines the protest is valid, the protest fee will be returned. For levels 3-5 events, if the Race Director determines the protest to be valid, he will meet with the Designated ROAR Official for discussion of a possible solution for this issue. For level 1 and 2 events, the Race Director may make the decision alone, but it is recommended that the solution be discussed with the other officials at the event.

5.15.12.6 If changes are made to any rules or procedures for the event as the result of a valid organizational protest, the Race Director must submit a written report of the protest and the action(s) taken to the ROAR President within two weeks of the completion of the event.

5.15.12.7 If the Race Director determines the protest to be invalid, the fee will be kept and the protest denied.

### 5.16 AWARDS

5.16.1 Awards for Level 2, 3, and 4 events should be plaques or trophies appropriate to the event being conducted. Awards at Level 1 events are at the discretion of the Race Director, and are not required when points are awarded leading to end of series or season awards. If awards are given at this level, ribbons, small plaques, or small trophies are recommended.

5.16.2 At Level 2 and 3 events it is recommended that a minimum of 15% of the entry fees be spent on awards. At level 5 events 15% of the total entry fees is the required minimum budget for awards and will be determined using the total entry fee amount collected by the registration deadline date, thirty days before the event. The style and quality of the awards will be the same throughout all classes and presented to at least the first three place finishers of all Mains.

5.16.3 No cash prizes or cash compensation awards are allowed at ROAR-sanctioned events. Any ROAR Club or Track conducting such an event will have its annual club membership voided and will be barred from holding a ROAR-sanctioned event for a period of one year from the violating event. **Note:** This ruling does not apply to individual non-sanctioned events that are publicized as being non-sanctioned, but does apply to any regularly scheduled level 1 events, as these are automatically considered to be ROAR-sanctioned events. (See 1.1.12 above)

5.16.4 All ROAR drivers participating in events outlined in rule 5.16.3 will have their memberships revoked, and will not be eligible for reinstatement for a period of one year. **Note:** ROAR does not restrict its members from competing in non-sanctioned events. This ruling therefore does not apply to ROAR drivers competing for cash prizes in non-sanctioned events held by non-affiliated clubs or tracks or affiliated tracks advertising non ROAR sanction with the exception of level 1, club events.

5.16.5 Merchandise, whether donated or purchased, may not be given as race awards. The use of merchandise certificates as race awards by a club is permitted, but the cash value cannot exceed the cost of an appropriate award. Selling raffle tickets for donated door prizes is not recommended unless there is agreement with the prize donor. Door prizes donated by manufacturers should be given away using a random selection process. Selling raffle tickets for organizer purchased prizes is allowed.

## 6 BODY, BUMPER AND WING RULES

### 6.1 BODY RULES

- 6.1.1 Bodies used in ROAR-sanctioned events must resemble vehicles used in full scale racing for the type of event being conducted. The ROAR Executive Committee will specify which body styles may be used in competition at sanctioned events.
- 6.1.2 Except for off road classes, only ROAR-approved bodies may be used in sanctioned events. For off-road bodies see rule 6.1.17.1.
- 6.1.3 **Body Approval process:**
  - 6.1.3.1 An Approved Body List is maintained by the ROAR Technical Director, and published on the ROAR website ([www.roarracing.com](http://www.roarracing.com)). If a body is not on the approved body list, it is not legal for use at ROAR-sanctioned events.
  - 6.1.3.2 The ROAR Administrator or Technical Director can provide full details of the submission process on request.
  - 6.1.3.3 To be approved, bodies must conform to the provisions of rule 6.1.17.2 and 6.1.17.3 below. The body manufacturer or distributor must submit samples of the body to the ROAR Body Committee, along with the required fee.
  - 6.1.3.4 All approved bodies are required to have the manufacturer's ID and Body number molded into the lower portion of the windshield or on the body below the point where a windshield would have been on the full scale counterpart. Otherwise, the proof of the legality of a questionable body is the responsibility of the driver.
- 6.1.4 When originally entered in an event, the body must be complete, neatly finished, painted, and trimmed. No clear areas except windshields and windows are allowed. No clear areas or stripes through body colors are permitted. No objectionable or suggestive art, decals, or lettering will be permitted.
- 6.1.5 Sharp or otherwise dangerous parts or features on a body are not permitted.
- 6.1.6 All vehicles must have a readily removable body. The body and chassis must be securely joined at all times while the vehicle is on the track. Rubber bands are not allowed for this purpose. If a body comes off a vehicle during a race, the vehicle must be taken off the track and the body properly replaced before the race may be resumed.
- 6.1.7 A realistically detailed driver figure consisting of at least a painted head, shoulders, and arms must be mounted or molded in all open cockpit bodies. When the driver figure is mounted as a separate item, the cockpit area of the body must be completely covered, with no open access to the chassis of the vehicle.
- 6.1.8 All molded-in windows must be clearly identified. Side and rear windows may be cut out unless otherwise stated in class rules or specifications. Open windshields are not allowed, except for holes defined in the relevant class rules or specifications. A sunshade band at the top of the windshield is permitted.
- 6.1.9 For closed-wheel bodies, no portion of the chassis, wheel, tire, or equipment may extend beyond the body except to the rear.
- 6.1.10 Openings in the body other than those appropriate to full-size vehicle openings such as grill, scoops, air vents, etc., must be kept to a minimum. Specifically servos, receivers, batteries, and servo savers are not allowed to protrude through the original body shell.
- 6.1.11 Wheel cutouts are allowed on the side plane of the body. They may not extend into the horizontal plane of the body. Wheel cutouts may not exceed the dimensions specified in

the relevant class rules or specifications. Wheel wells must be cut out if the original vehicle ran that way.

- 6.1.12 Antenna openings in the body may not exceed .375" in any direction.
- 6.1.13 Cooling holes: Bodies for on-road fuel-powered cars (other than touring vehicle bodies) may have up to 1/3 of the windshield cut out. Bodies used on off-road fuel-powered cars may have up to 1/2 the windshield cut out. For touring vehicle windshields, one cooling opening is permitted, limited to a maximum of 60mm in any direction.
- 6.1.14 Refueling holes: A refueling hole is permitted in any body type for fuel-powered cars. The following restrictions apply:
- 6.1.14.1 The hole must be centered directly above the fuel tank filler neck
- 6.1.14.2 For bodies where the fuel filler cap extends above the body when open, such as Sports/CanAm or off road buggy bodies, the clearance of the hole to the filler cap may not exceed .375" in any direction.
- 6.1.14.3 For closed-roof bodies, such as Touring Car bodies, where the filler cap does not extend above the body roofline when open, the hole may be a maximum of 30mm in any direction, and may not intersect with any other hole in the body. Holes for use of the glow igniter and carburetor tuning are allowed.
- 6.1.15 Unless otherwise stated in the relevant class rules or specifications, the rear section of a body may be cut out as long as the rear sides and quarter panels, including the taillights and side portion of the rear bumper remain intact. It is recommended that some portion of the cut line remain visible to help speed technical inspection. If the body has no lower body trim line, then the fold line is considered the cut line.
- 6.1.16 Body components must remain on the vehicle, except for accidental race damage.
- 6.1.17 The following body types are authorized for use on the various track surfaces:
- 6.1.17.1 **OFF-ROAD BODIES**
- 6.1.17.1.1 Buggy and truck bodies used in ROAR-sanctioned events should resemble those used in full scale off-road and stadium racing. Sedans, out-of-scale truck, and van bodies are prohibited.
- 6.1.17.2 **ON-ROAD BODIES**
- 6.1.17.2.1 These include four general categories:
- Sports Cars: Closed wheel cars designed specifically for racing in full-size series such as CanAm, GTP, WSC, ALMS, etc.
  - GT Cars: Modified versions of two door street cars such as GT, GT-1, TransAm, and T-1 Touring Cars
  - Touring Cars: Two- or four-door sedans that have competed in a full-size Touring Car series.
  - Open wheel cars: Single seat, open wheeled cars that compete in CART, Formula 1, IRL and other similar formats.
- 6.1.17.3 **OVAL BODIES**
- 6.1.17.3.1 These include:
- American-style Modified Stock Car (includes Outlaw Wedge and super modified),
  - Trucks such as those used in NASCAR Truck racing
  - Sprint Cars
  - Stock Cars, such as those used in NASCAR
- 6.2 BUMPER RULES**
- 6.2.1 Bumpers are not required in all classes, but when used, they must be shock absorbing and non-metallic, with no sharp edges. For safety, rigid bumpers, such as fiberglass and composites, are not permitted.

- 6.2.2 Front bumpers must be of at least 1/8" material (3/32" for 1/12). Bumpers will not extend forward of the body except on off-road cars. The bumper may not extend to the side beyond the outer edge of the tires.
- 6.2.3 Rear bumpers must be made of a solid material with rounded edges and may not extend to the side beyond the outer edges of the tires, and may not extend beyond the rearmost part of the body except in off-road vehicles.

### **6.3 SPOILER RULES**

- 6.3.1 Definition: For the purposes of these rules, a spoiler is a flat plate attached to a body or to the trailing edge of a wing in order to increase down force and traction when a vehicle is traveling at speed. Except for F1/Indy Cars and Sprint Cars with front and rear wings, they are always located at the upper rear portion of the body.
- 6.3.2 Many R/C racing bodies have molded spoilers. In some classes, additional material may be added to increase the height of the spoiler. Where this is permitted by the class rules or specifications, the dimension specified includes the molded spoiler.
- 6.3.3 Spoilers may not extend beyond the width of the body.
- 6.3.4 Where permitted, add-on spoiler material must be securely fastened to the body.
- 6.3.5 Spoiler side plates when used must conform to the class specific rules.
- 6.3.6 Spoilers may be clear or painted, and may carry stickers.

### **6.4 SIDE DAMS**

- 6.4.1 Definition: Side dams are flat plates applied to the sides of bodies to increase the directional stability of the vehicle when traveling in a straight line, or to the sides of wings to increase the efficiency of the wing. The use of side dams is permitted in some classes, as indicated in class rules or specifications.
- 6.4.2 Side dams are normally used as a part of a wing set. The only exception to this rule is the modified stock vehicle, which may use one side dam attached to the body. If used, the top must be securely fastened to the opposite side of the body at the front and rear of the dam.
- 6.4.3 On Oval racing cars, two side plates are required on the wing. The side plate may extend below the wing chord (within the dimensional limitations defined in the relevant class specifications) but may not touch the body.

### **6.5 WINGS**

- 6.5.1 Definition: Wings are aerodynamic devices attached to vehicles to increase down force and traction when a vehicle is traveling at speed. The dimensions of wings vary depending on the class of racing, and are described in class rules or specifications.
- 6.5.2 Only single element or two-element wings may be used, and then only when allowed by the class rules.
- 6.5.3 Wing mountings:

- 6.5.3.1 Wings should be mounted using wire or some other secure mounting system, and be no closer than 1/4" to the body except as provided below. The distance between the wing and the body is measured between the rear deck of the body and the flat portion of the wing chord.
- 6.5.3.2 Off-road wings may be mounted using wire or fastened directly to the chassis. There is no minimum clearance for off-road wings. Front wings are allowed if utilized on the body's full-scale counterpart. If allowed, front wing dimensions are specified in the class rules.
- 6.5.3.3 On-road wings, when permitted, may be mounted directly to the body without clearance. Front wings are allowed if utilized on the body's full-scale counterpart. Driver must show proof of full-scale utilization.
- 6.5.3.4 Oval wings may be mounted to or through the rear window of the body.
- 6.5.4 In some classes, wings and spoilers may be used in combination. When allowed by the class rules, separate specifications are provided.

## **7 WHEEL AND TIRE RULES**

### **7.1 GENERAL RULES**

- 7.1.1 All cars used in ROAR competition must be designed to have four wheels that support it while in motion. No three-wheeled cars or cars with dual wheels in any position are permitted.
- 7.1.2 Any wheel manufactured for R/C vehicle competition may be used as long as it meets the class specifications. Wheels will be secured to the axles by means of lock nuts, screws, or quick-release axle ends. Nuts or axles will not protrude more than 1/16" beyond the outer edge of the tire. When nuts and/or axles extend beyond the wheel or tire, they will be included when measuring the vehicle's overall width.
- 7.1.3 Any tire produced for R/C competition may be used as long as it meets the definitions below and the specifications for the class. Tires must be securely fastened to the wheels. Rubber tires used for off-road classes may only be used in the classes for which they were originally manufactured. The modification of tires from one class to fit vehicles of another class is not allowed.

### **7.2 WHEEL RULES**

- 7.2.1 The elements of wheel measurement are as follows:
  - 7.2.1.1 Mounting bead- the dimension measured at the point where the tire bead meets the wheel.
  - 7.2.1.2 Maximum wheel diameter- the largest diameter of the wheel not including the molded in ridges of on-road wheels to keep the tire in place
  - 7.2.1.3 Wheel width- the measurement at the widest portion of the wheel.
  - 7.2.1.4 Internal locking rings may only be used to retain the tire. Rings cannot be used to increase wheel size or to stiffen the sidewall.
- 7.2.2 Stick-on wheel disks are not allowed. Unless other means are authorized by the Race Director, the disks must be secured to the wheel by the axle nut or screws.

## 7.3 TIRE RULES

- 7.3.1 Tires used in R/C competition are defined as follows:
- 7.3.1.1 Rubber: A tire molded using rubber or similar synthetic material. Tires may be smooth, spiked, or treaded. Foam inserts are allowed but may not be bonded or glued to the tire. Pre-built rubber tire/insert/wheel combinations are allowed as long as inserts are not bonded or glued to the tire.
  - 7.3.1.2 Foam: A tire composed solely of foam rubber. Tires may be bonded to the wheel. No bonded coatings are allowed.
  - 7.3.1.3 Capped: A tire molded using rubber or similar synthetic material which is bonded or laminated to a core of foam rubber.
- 7.3.2 Tires that may be used in the various classes are described in the type or class rules.
- 7.3.3 Silicone capped or coated tires are not permitted in any class.
- 7.3.4 Tires will be black except for sidewall lettering. Foam tires may have an identifying foam stripe.
- 7.3.5 No metal, rigid plastic or synthetic spikes or sections may be added to the tires.
- 7.3.6 No more than 1/16" of wheel rim may be exposed on the outside of the wheels.
- 7.3.7 Tire width cannot exceed wheel width unless specifically allowed in class specifications.
- 7.3.8 The use of commercially available traction compounds and/or tire cleaners at any ROAR event is at the discretion of the Race Director and any bans or special requirements must be disclosed in advertising, on race entry forms, and in track rules.
- 7.3.9 At carpet races, tire cleaners and traction compounds that can coat the track are not allowed.
- 7.3.10 For health and safety reasons, diesel fuel, and any personally developed traction chemicals and/or tire cleaners are not allowed at any ROAR event.
- 7.3.11 Using an open flame to heat tires and/or burn tires is not allowed at any ROAR event.

## CLASS-SPECIFIC RULES

The following rules are additional rules for specific classes. In most cases, the rules in this section are designed to further define the General Rules. At no time are these class-specific rules to be used without regard to the General Rules, which apply to all vehicle types and classes. If a rule in this section differs from a General Rule, this section's rule takes precedence.

### 8 RULES FOR ELECTRIC CLASSES

#### 8.1 ELECTRIC RACING RULES

- 8.1.1 Restarts are permitted if the Race Director believes one or more drivers have gained an unfair advantage. (See Rule 5.14.5 regarding jump starts)

#### 8.2 GENERAL ELECTRIC VEHICLE RULES

- 8.2.1 "Roll-over" antennas are allowed in on-road classes only, not in any oval or off-road classes. The exposed ends of such antennas must be fitted with a button or ball having a diameter of at least 5/16".
- 8.2.2 For those electric classes where a "straight axle" is specified, the following definition applies: In a straight axle design, there must be a fixed relationship between the axle and the motor. No relative movement is allowed between the rear axle bearings and the motor case, and all suspension action must be applied to the motor, transmission and both rear wheels as a unit.

#### 8.3 BATTERY RULES

- 8.3.1 Only Ni-Cd or NiMh sub-C size rechargeable batteries rated at 1.2 volts or less may be used for the motor power in electric vehicle racing.
- 8.3.2 Dimensions:
- 8.3.2.1 Diameter: Maximum 23mm, Minimum 21.5mm
- 8.3.2.2 Length: Maximum 43mm, Minimum 41.5mm
- 8.3.2.3 No further tolerances are allowed on these dimensions.
- 8.3.3 Batteries must receive ROAR approval to be legal for use in ROAR-sanctioned events. Cells submitted for approval shall measure 43.0mm in can length which does not include the center positive button. Individual cells shall be constructed such that the total overall length resulting from the combination of charging and/or conditioning never exceeds 44.0mm. This may be verified at competition technical inspections.
- 8.3.4 The approval of new battery types, makes, or capacities must be published in Rev-Up ONLINE! or posted on the [www.roarracing.com](http://www.roarracing.com) website. The Executive Committee has final approval over battery legality.
- 8.3.5 Only manufacturers, distributors, or commercial-level assemblers may submit batteries for approval.
- 8.3.6 Battery approvals will be processed on a bi-yearly basis. All proposed cells must be received by the ROAR Technical Director by the 1st of September for approval by October 1st or received by April 1st for approval by May 1st. The final decisions on approvals will be communicated to the manufacturer/distributor or assembler and posted on the website listing when approved.
- 8.3.7 Ni-Cad batteries must bear the RBRC recycling logo in order to be approved.



- 8.3.8 To be approved by ROAR, batteries must be available through hobby distributors and hobby dealers nationwide at a competitive retail price.
- 8.3.9 Batteries must be readily identifiable as to their origin. In the case of a secondary, or distributor label being available and applied by the original manufacturer at the factory, a Statement of Origin/ Manufacture must be provided to ROAR from the original manufacturer via the reseller for any individualized cell. This label must state the country of manufacture and have the voltage and capacity rating in milliAmp-hours (mAh) printed on it. All individualized cells must be presented to ROAR for approval.
- 8.3.10 Any indication that the original manufacturer-applied label has been changed or tampered with will make the battery illegal. If the cells have an identifying mark on the negative end, the mark must be visible after the battery has been soldered together.
- 8.3.11 If protested, it is up to the driver to prove the legality of his batteries. It is recommended that when cells are assembled into a pack that the cells be arranged so all pertinent information on the cells is clearly visible. If cells are glued together, a glue should be used that can be cut without damaging the cell's shrink-wrap.
- 8.3.12 Batteries may not be charged or changed during a standard length race. Batteries may be changed during an Endurance race.
- 8.3.13 Unless a lower number is specified in the class requirements, a maximum of six cells is permitted in any vehicle motor power pack used in ROAR-sanctioned competition.
- 8.3.14 Drivers are responsible for the proper disposal of batteries that are no longer useable. No batteries should be discarded in ordinary trash containers, and may not be abandoned at race sites. It is recommended that tracks promote safety and non-pollution by providing an approved disposal container for unusable batteries.

## **8.4 ELECTRIC MOTOR RULES**

### **8.4.1 GENERAL RULES:**

- 8.4.1.1 All motors must meet ROAR specifications, as verified by an independent laboratory, before the ROAR Executive Committee will approve them.
- 8.4.1.2 The approval of new motors must be published in Rev-Up or posted on the [www.roarracing.com](http://www.roarracing.com) website for those motors to be legal for use in ROAR-sanctioned competition.
- 8.4.1.3 All electric motors are subject to inspection, and may be torn down at the discretion of the Race Director.
- 8.4.1.4 At Level 1-4 events, the motors used in the first, second, and third place cars in the A main will be inspected and may be torn down.
- 8.4.1.5 At Level 5 events, all A main motors will be inspected and if the Race Director suspects any foul play, the motors of the top three finishing vehicles will be torn down, to include unwinding at least one pole of stock motors. If a stock motor is torn down and it is legal, it will be replaced if requested. If it is illegal, the driver will be disqualified.
- 8.4.1.6 Any motor found to be in deliberate violation of any specification will result in the OEM Importer/ Manufacturer/ Builder to have their products banned from any ROAR approval for a period of one year.

### **8.4.2 SPECIFICATIONS AND DIMENSIONS:**

- 8.4.2.1 Only industry standard "05" size motors may be used.
- 8.4.2.2 All motors must have the original manufacturer's logo or name molded or etched into the end bell.
- 8.4.2.3 Can must have the original manufacturer's logo, name or mark.
- 8.4.2.4 Overall maximum diameter: 36.02mm measured at whatever point yields the maximum dimension.
- 8.4.2.5 Maximum length: 53mm measured from the mounting face of the motor to the furthest most point of the end bell, not including solder tabs or lead wires.

- 8.4.2.6 Shaft diameter: 0.125".
- 8.4.2.7 Motor mounting holes must be on 1.00" centers.
- 8.4.2.8 Maximum Armature stack length: 22.6mm
- 8.4.2.9 Maximum Armature stack diameter: 23.2mm.
- 8.4.2.10 Only three pole armatures are permitted.
- 8.4.2.11 Magnets: Only ceramic, Neodymium, or Ferrite magnets are permitted. Cobalt and other rare earth magnets are specifically prohibited.

8.4.3 **MOTOR APPROVAL PROCEDURE:**

- 8.4.3.1 Only manufacturers, distributors or commercial-level motor tuners may submit motors for approval.
- 8.4.3.2 Samples of new motors should be submitted to the ROAR Technical Administrator and motor laboratory for approval prior to actual production.
- 8.4.3.3 Once passed by the laboratory, approval will be granted when proof is submitted that a minimum of 5,000 stock or super stock motors, or 2,000 modified motors have been produced and are available for sale in the USA and Canada.
- 8.4.3.4 Contact the ROAR Technical Administrator or ROAR Administrator for more information on the approval process and fees.
- 8.4.3.5 If an approved motor is changed in a substantial way, such as: can color, orientation of the brushes, end bell color or configuration, or date stamp; it must be resubmitted for approval. This includes any internal changes to the armature or commutator.
- 8.4.3.6 All approved motors are subject to spot-checking at any time by the ROAR Technical Administrator to verify that they are still in compliance with ROAR specifications.

## 8.5 STOCK MOTOR RULES

- 8.5.1 Stock motors are available in two types:
  - Fixed end bell stock motors: These are the traditional stock motors where the end bell is permanently attached to the motor can in order to discourage tampering with the armature. Specifications for this type of stock Motor are contained in section 8.5.5 below.
  - Rebuildable stock motors: These motors feature end bells that are removable but have fixed timing, allowing the motor to be rebuilt. Special identification requirements for rebuildable stock motors are defined in section 8.5.6 below.
- 8.5.2 Where a specification or rule makes no specific reference to the type of stock motor in these rules, the requirement applies to both fixed end bell and rebuildable stock motors, unless specifically stated otherwise in the type-specific requirements.
- 8.5.3 **GENERAL:**
  - 8.5.3.1 Motors submitted for approval for use in both stock classes must have "ROAR XX" permanently stamped into the mounting face of the motor can (XX is the year of initial manufacture). Use of the "ROAR XX" or "R/N 5° STK" stamp on any motor that has not been submitted for approval is strictly prohibited. Any deliberate violation of this rule will be cause to remove all motors of that manufacturer from the approved list for a minimum of one year.
  - 8.5.3.2 Approved stock motors must be commercially available through hobby distributors and hobby dealers nationwide for a maximum retail price of \$46, including any after market tuning and preparation.
- 8.5.4 **CONSTRUCTION:**
  - 8.5.4.1 The armature shafts of stock motors must turn in bushings only. The use of any device or attachment that allows the output shaft of a stock motor to ride in a ball bearing is strictly prohibited.

- 8.5.4.2 Timing advance must be fixed at a maximum of 24 degrees measured mechanically. The space between the magnets must be centered on one set of mounting holes, and marked on one side of the can to indicate zero degrees. The brush hoods will be aligned at 90 degrees from this mark, plus the allowed timing. The commutator slots must be aligned with the center of the armature pole faces. A tolerance of two degrees is allowed on the commutator positioning, but not on the overall timing.
- 8.5.4.3 Only two single-piece magnets are allowed.
- 8.5.4.4 Stock motors must be machine wound using a "Mabuchi" cross wrap technique, and must incorporate a design that locks the commutator to the armature stack so that the timing cannot be changed without disassembling the motor.
- 8.5.4.5 Armatures must be machine wound with a minimum of 64 inches of round 22 AWG (American Wire Gauge) wire, having a maximum wire diameter (including insulation) of .67mm, resulting in no less than 27 continuous turns of wire on each pole. A production tolerance of one turn on one pole is allowed. There is no tolerance on the minimum length of wire or a plus tolerance on wire diameter.
- 8.5.4.6 The tabs on the armature's commutator may only be "compression welded". After-market welding or silver brazing is not permitted.
- 8.5.4.7 Epoxy balancing of armatures for stock motors is not permitted.
- 8.5.4.8 Magnets must be permanently glued to the motor can and may not be removed. No magnet shims are allowed (e.g., an extra shim that could be added on the end of the magnet or between the tips to change performance). Flux collector or timing rings are allowed on rebuildable stock motors as long as their only purpose is to secure the end bell to the motor can. No part of these rings may extend between magnet tips.
- 8.5.4.9 The end bell may have inspection or cooling holes on each side between the negative and positive terminals. End bells must be permanently marked with manufacturer's name.
- 8.5.4.10 The hole for the bushing in both the end bell and the motor can may not be smaller than .210" diameter. This will allow easy verification that the motor bushings have not been replaced with ball bearings and inspection will not require disassembly of the motor.

#### **8.5.5 MODIFICATIONS ON FIXED END BELL STOCK MOTORS:**

- 8.5.5.1 No modifications are allowed that require disassembly or internal work on a fixed end bell stock motor. This includes re-balancing, re-forming the can, re-epoxying, adding ball bearings, and modification of the brush hood system, removing the endbell, and adding or removal of material or parts.
- 8.5.5.2 Motor brushes and brush springs may be modified or replaced on external brush system motors.
- 8.5.5.3 Commutators may be lathe trued. This may only be done by removal of the brush hoods. The original brush hoods must be replaced in the original factory position. Any further disassembly or modification of a fixed end bell stock motor is prohibited.
- 8.5.5.4 If a fixed end bell stock motor shows signs of tampering during post race inspection, the driver will receive no score for that qualifier or main. At events where "hand out" fixed end bell stock motors are provided, the driver is responsible for any signs of tampering.

#### **8.5.6 REBUILDABLE STOCK MOTORS**

- 8.5.6.1 Motors submitted for approval as rebuildable stock motors must have the manufacturer's name in the form of "XXXX 27" (e.g. EPIC 27, YOK 27, etc.) permanently stamped into the mounting face of the motor can. "XXXX 27" designates the use of the can for Stock class racing. The manufacturer name on the can will make hybrid motors easy to identify. Any deliberate violation of this rule will be cause to remove all motors of that manufacturer from the approved motor list for a minimum of one year.

- 8.5.6.2 The end bell and can of a rebuildable stock motor must incorporate a molded tab that keys into a slot on the can, locking the timing at 24 degrees. This feature is in addition to any method that secures the end bell to the can (e.g., screws running through the side of the can). The end bell timing may only be set at 24 degrees. Extra locking devices (e.g., extra notches in the motor can that allow timing to be changed to 36 degrees or 5 degrees) are not allowed.
- 8.5.6.3 The Motor can must have inspection holes or slots between magnet tips so that the armature may be viewed for inspection of armature tag (see 8.5.6.4). These holes or slots may be no closer than .220" from the top or bottom edge of the motor can. The View through the inspection holes or slots must not be obstructed by anything covering the holes/slots (e.g. motor label).
- 8.5.6.4 The armature of a rebuildable stock motor must be tagged in a way that it is easy to identify both in and out of the motor. The tag must be permanently affixed to the armature and made of a material that will not be destroyed by from the heat of the motor or by standard motor cleaning agents. The tag should be positioned between two poles of the armature and must be a minimum of .500" in length. The tag must be printed with the OEM manufacturer's name and "27" (e.g., "EPIC 27", "YOK 27", etc.).
- 8.5.6.5 The armature shaft must extend .125" beyond the end bell bushing when the motor is assembled. The overall length of the armature shaft should be 2.775" with .385" extending beyond the end of the commutator. The commutator end of armature shaft must be coned or tapered and must differ visually from the standard radius currently used by OEM manufacturers in production of other motors. The taper should continue for a minimum of .060" from the end of the shaft.

**8.5.6.6 MODIFICATIONS ON REBUILDABLE STOCK MOTORS:**

- 8.5.6.6.1 No modifications to the physical construction of the motor can, endbell, or armature will be permitted (e.g. adding or removing material from the armature stack, changing the brush hoods from stand up to lay-down and visa-versa, relocating spring posts).
- 8.5.6.6.2 If a rebuildable stock motor shows signs of any of these modifications during post race inspection, the driver will receive no score for that qualifier or main.
- 8.5.6.6.3 The armature, motor can, and endbell of a rebuildable stock motor must all be from the same motor manufacturer and can contain only components from the same model. No hybrid motors or mixing of parts from different models will be permitted.

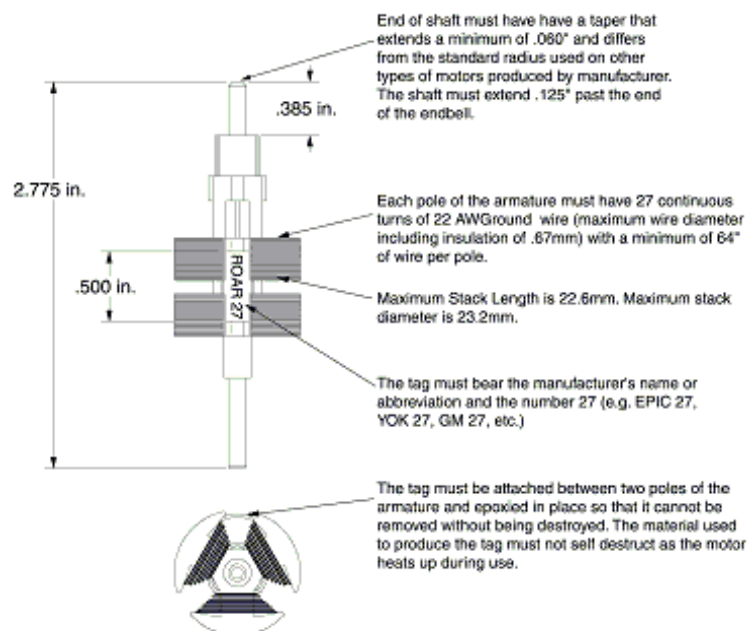

## 8.6 19T REBUILDABLE “SUPER-STOCK” MOTOR RULES

- 8.6.1 Motors in this class are intended for On-road and Off-road racing, not for Oval racing. Oval racing 19T motors are described under the Modified Motor section of these rules (see 8.8 below)
- 8.6.2 Motors submitted for approval as rebuildable 19T “Super Stock” motors must have the manufacturer’s name in the form of “XXXX 19” (e.g. EPIC 19, YOK 19, etc.) permanently stamped into the mounting face of the motor can. “XXXX 19” designates the use of the can for 19T “Super Stock” class racing. The manufacturer name on the can will make hybrid motors easy to identify. Any deliberate violation of this rule will be cause to remove all motors of that manufacturer from the approved motor list for a minimum of one year. All motors submitted for approval shall be freely commercially available at a retail price of less than \$60.
- 8.6.3 All ROAR rebuildable 19T “Super Stock” motors may be either bearing- or bushing-type with an endbell that locks the timing at 24 degrees. The space between the magnets must be centered on one set of mounting holes, which will be marked on one side of the can to indicate zero degrees. The brush hoods will be aligned at 90 degrees from this mark, plus the allowed timing. The commutator slots must be aligned with the center of the individual poles. A two-degree tolerance will be allowed on the commutator, but not on the overall timing. Endbell must include a mark indicating 24-degree timing adjustment when motor is assembled. Only single-piece (two magnets in a can), or split (four magnets in a can) ceramic magnets are allowed. With single piece magnets, the center of each magnet must be 90 degrees from the 0 degree timing mark on the can. Split magnets must have the split in the segments centered at 90 degrees from the 0 degree timing mark on the can and all four segments must be of the same length. Offsetting single piece or split magnets with the intent of increasing motor performance/ timing is not allowed.
- 8.6.4 Endbell and can must be designed with a method of locking the timing at 24 degrees. This feature is in addition to any method that secures the endbell to the can (e.g., screws running through the side of the can). The endbell must incorporate a molded tab that keys into a slot on the can, locking the timing at 24 degrees. Endbell timing may only be set at 24 degrees. Extra locking devices (e.g., extra notches in the motor can that allow timing to be changed to 36 degrees or 5 degrees) are not allowed.
- 8.6.5 Endbells may have inspection/cooling holes on each side between the negative and positive terminals. These holes would facilitate inspection of commutator tabs. Endbells must be marked with manufacturer’s name.
- 8.6.6 The brush configuration may be of any type as long as that configuration appears on a previously ROAR approved modified or stock motor.
- 8.6.7 The motor can must have inspection holes/slots between magnet tips so that the armature may be viewed for inspection of armature tag (see 8.6.14). These holes/slots may be no closer than .220” from the top or bottom edge of the motor can. View through inspection holes/slots must not be obstructed by anything covering the holes/slots (e.g. motor label).
- 8.6.8 Magnets must be permanently glued to the motor can and may not be removed. No magnet shims are allowed (e.g., an extra shim that could be added on the end of the magnet or between the tips to change performance). Flux collector/timing rings are allowed as long as their only purpose is to secure the endbell to the motor can. Rings may not extend between magnet tips.

- 8.6.9 Rebuildable 19T “Super Stock” motor armatures must be machine-wound using a cross-wrap technique. Armatures machine-wound using a hemi-wrap technique will be allowed beginning July 31, 2007. The legal 19T “Super Stock” wind is a minimum of 1170mm of round 19 AWG (American Wire Gauge) wire, having a maximum wire diameter (including insulation) of .914mm, resulting in no less than 19 continuous turns of wire on each pole. There is no tolerance on the minimum length of wire, nor is there a plus tolerance allowed on the wire diameter.
- 8.6.10 Tabs on the armature’s commutator may only be “compression welded”. No after-market welding or silver brazing will be permitted. The Commutator must be locked to the armature laminations to prevent timing changes by twisting of the armature shaft.
- 8.6.11 Deleted, repeated in 8.6.3.
- 8.6.12 No split, skewed, or tri-rotor armature stacks are allowed. The coated magnetizable stacks will have a maximum length of 22.6mm and a minimum length of 19.0mm. Originally manufactured longitudinal slots centered in the pole crowns may be no wider than .032in (0.8mm.) These are limited to one per pole and must be parallel to the armature shaft. No secondary machined slots are permitted. The crowns of each armature pole must be symmetrical in cross section, with a constant crown radius. Steps in the crown or longitudinal holes in the crown are not allowed.
- 8.6.13 No modifications to the stack may be made other than the machining of balancing marks. Modifications to the original OEM/Importer/Manufacturer configurations, including but not limited to excessive machining, milling or turning to lighten the armature, or enhance the performance of the full stack are not allowed.
- 8.6.14 Armature must be tagged in a way that it is easy to identify both in and out of the motor. The tag must be permanently affixed to the armature and made of materials that will not self destruct from the heat of the motor or standard motor cleaning agents. The tag should be positioned between two poles of the armature and must be a minimum of .500” in length. The tag must be printed with the OEM manufacturer’s name and “19” (e.g., “EPIC 19”, “YOK 19”, etc.).
- 8.6.15 Armature shaft must extend .125” beyond the endbell bushing when motor is assembled. The overall length of the armature shaft should be 2.775” with .385” extending beyond the end of the commutator. The commutator end of armature shaft must have a machined “step” that differs from the standard radius or taper currently used by OEM manufacturers in production of other stock or modified motors. The step should continue for a minimum of .060” from the end of the shaft.
- 8.6.16 No modifications to the physical construction of the motor can, endbell, or armature will be permitted (e.g. adding or removing material from the armature stack, changing the brush hoods from stand up to lay-down and visa-versa, relocating spring posts). If a motor shows signs of tampering during post race inspection, the driver will receive no score for that qualifier or main.
- 8.6.17 Epoxy balancing and machined balancing methods are permitted. If epoxy balancing is used, then no more than two balancing marks are permitted on the entire armature. If only machined balancing is used then no more than five balancing marks are permitted on the entire armature. Machined balancing consists of drilled holes or grinding marks made only on the pole centerlines.
- 8.6.18 The armature, motor can, and endbell of a rebuildable 19T “Super Stock” motor must all be from the same motor manufacturer and may only contain components from the same model. No hybrid motors or mixing of parts from different models will be permitted.

# 19T "SUPER-STOCK" MOTOR ARMATURE

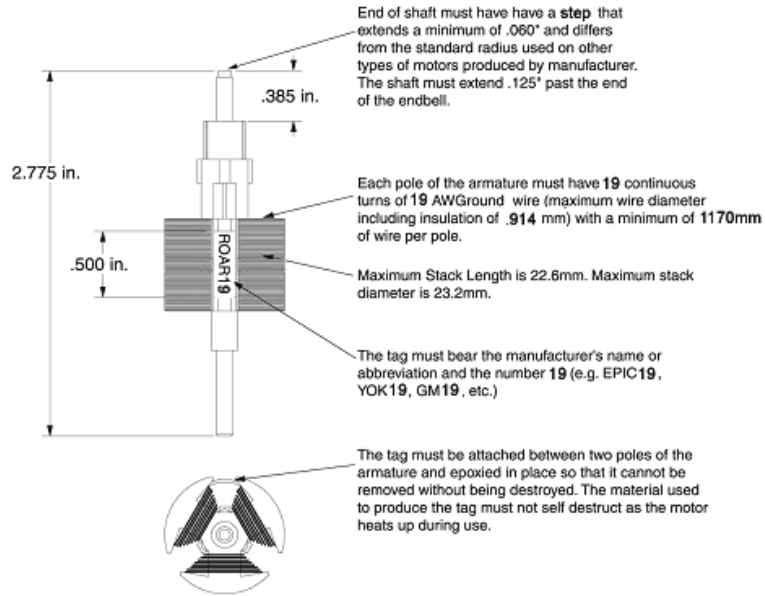

## 8.7 MODIFIED MOTOR RULES

- 8.7.1 Modified motors must conform to technical specifications in Rule 8.4 above
- 8.7.2 The base motor may be modified by re-winding, epoxying, balancing, adding cooling holes, ball bearings, and custom brush systems. The original armature, commutator, magnets, motor can, and endbell must be used, but may be modified. No mixing of parts from different base motors is allowed.
- 8.7.3 Approved modified motors must be commercially available through hobby distributors and hobby dealers nationwide for a maximum retail price of \$110.
- 8.7.4 Rule deleted 2005 (10 turn limitations):
- 8.7.5.0 Brushless Motors are approved for modified racing only.
- 8.7.5.1 Sensored or sensorless motors are allowed.
- 8.7.5.2 The motor has to be rebuildable. Ball bearings are allowed.
- 8.7.5.3 If the motor is sensored:  
It must use a six position JST ZH connector model number ZHR-6 or equivalent connector with 6 JST part number SZH-002T-PO.5 26-28 awg contacts or equivalent.  
Wire sequence must be as follows:  
Pin #1- Black wire-ground potential  
Pin #2- Orange wire-phase C  
Pin #3- White wire-phase B  
Pin #4- Green wire-phase A  
Pin #5- Blue wire-temp control, 10 k Thermistor referenced to ground potential  
Pin #6- Red wire-+ 5.0 volts  $\pm$  10%  
For clarification pin #1 is on the left hand side of the above connector with the wires exiting the top of the connector and the plastic tangs that hold the contacts in the housing are facing forward. See drawing below.

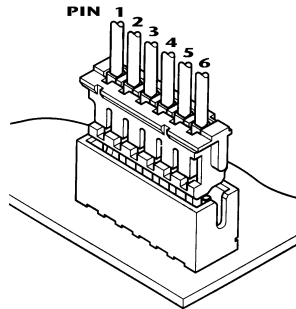

Compatible speed control must use the six position JST header part number X-6B-ZR-SMX-TK (where the X denotes the style of the header), or equivalent.  
The power connector has to be clearly marked A, B, C. on both speed control and motor.  
A for phase A  
B for phase B  
C for phase C



8.7.5.4 "05" size dimensions.

**Can:**

Overall maximum diameter is 36.02mm measured at whatever point yields the maximum dimension, excluding solder tabs or lead wires. Overall minimum diameter is 34.00mm measured at whatever point yields the minimum dimension, excluding solder tabs or lead wires. Maximum length is 53.00mm measured from the mounting face of the motor to the furthest most point of the end bell, not including solder tabs, lead wires or original manufacturer's logo or name. Minimum length is 50.00mm measured from the mounting face of the motor to the furthest most point of the end bell, not including solder tabs, lead wires or original manufacturer's logo or name. Motor mounting holes must be on 1.00- inch (25.40mm) centers.

**Stack/Stator:**

Stack minimum length 19.30mm, maximum 21.00mm. Stack inside diameter minimum 12.50mm, maximum 16.00mm. If a continuous stack is used then the laminations have to be adjacent to one another without any insertions. The thickness of the stack plates is 0.35 +/- 0.05mm. All laminations must be of the same material.

**Winding:**

Only three slot (phase) "Y" wound stators are permitted. No delta wound stators allowed. Only circular (round) pure copper wire permitted. No turn limit.

**Rotor:**

Shaft diameter must be 0.125 inches (3.175mm). Only one piece, two pole Neodymium or Ferrite magnetic rotors are permitted. Magnet minimum length 23.00mm, maximum 27.00mm. Magnet minimum diameter 12.00mm, maximum 15.50mm.

8.7.5.5 All motors must have the original manufacturer's logo or name molded into the end bell.

8.7.5.6 A minimum of two thousand (2000) brushless motors must be available at the time of approval. A minimum of three hundred (300) brushless motors must have been sold to at least three (3) distributors or hobby shops or OEM's at the time of submittal. The manufacturer has to provide an address of a hobby shop or the like, that any driver who wishes to obtain these motors at the time of the approval can do so. No hybrid (mixing of parts from approved brushless motors) allowed.

8.7.5.7 The maximum retail price of a modified brushless motor shall be \$129.00

## 8.8 19T MODIFIED OVAL MOTOR RULES

8.8.1 The rules contained in this section apply to the 19T modified class for Oval racing only.

8.8.2 **GENERAL:**

8.8.2.1 19T Modified oval motors may be based on any ROAR-approved modified motor combination (can, endbell and armature).

8.8.2.2 Suggested retail price for a complete motor shall not exceed \$65. Suggested retail price for an armature shall not exceed \$30. Suggested retail price of a can and endbell combination shall not exceed \$30.

8.8.2.3 ROAR Oval Committee will annually review and evaluate the specifications herein for quality of race competition, present manufacturing processes/ materials, changes in technology and track performance.

8.8.3 **ARMATURES:**

8.8.3.1 3 pole armatures only, with a minimum stack length for Epic of 21.3 mm; Yokomo 21.3 mm; Top Core 21.5mm; Vortex 21.5 mm with a minimum stack diameter of 22.9 mm. Full stack armatures only, no split rotors or tri- rotors are permitted. Minimum web thickness shall be 0.170 inches (4.33 mm) including manufacturing applied epoxies to secure stack

wafers. No removal of stack wafers (i.e. short stacking) allowed. Armature shaft diameter will be 0.125 inches.

- 8.8.3.2 All armatures will be wound with the "Mabuchi" cross wrap from only round 19 AWG wire with a maximum size of 0.0355 inches (0.902 mm) bare, and a minimum of 19 continuous turns per pole. No error factor in the number of winds per pole/ stack will be allowed. Wire length will be a minimum of 134 inches total, or 44.60 inches unwound per pole. No shorting of any wind or winds allowed.
  - 8.8.3.3 Armatures may be hand or machine wound, and must bear a mark or tab identifying the armature and winder. Example: NAME 19X1, NAME 19T. Marks may include etching or engraving of the armature stacks and/ or tags epoxied between the stack spacing and must be permanent, as to see any tampering. If it is found that these markings/ tabs/ tags are not legible, or tampered with, the armatures may be deemed illegal. Unmarked armatures will be deemed illegal and may result in forfeiture of main or qualifier.
  - 8.8.3.4 The commutator slots must be aligned to neutral with the center of the individual poles/ segments. No tolerance allowed on commutator timing. Skewed commutator segments are not legal.
  - 8.8.3.5 Full stack armatures made only of magnetizable material. No modifications to the stacks will be allowed other than the normal drill balance holes. Any modifications to the original OEM Importer/ Manufacturer configurations, including but not limited to, excessive drill holes/ milling/ turning to lighten and/ or enhance the performance of that of a full stack armature will not be allowed. No linear separations of the stack segments will be allowed.
  - 8.8.3.6 Vertical slots will not be allowed on any armature manufactured by the OEM after January 1, 2002. Vertical slots on all armatures manufactured prior to January 1, 2002 will not be modified from the original configuration. At no time will any material be removed from the armature, whether hidden or visible, except those from the normal balance holes as specified here within. No skewed armature laminations allowed.
  - 8.8.3.7 Balancing may be done by either epoxy and/ or drill balancing. Drill marks shall not exceed two holes per pole with a number 1 or number 2 combination drills/countersink. Holes may not be larger than 0.1875 inches (4.76 mm) in diameter and may not exceed 0.250 inches (6.35 mm) in depth. Any large drill holes of the same size, on all three stacks, shall be suspect to excessive drilling for the purpose of lightening and/ or enhancing the performance and is not allowed.
- 8.8.4 CAN and ENDBELL:**
- 8.8.4.1 The space between magnets will be centered at one set of the mounting holes, which will be marked to indicate zero degrees (0) centerline.
  - 8.8.4.2 Magnets must be permanently affixed/ epoxied to the can and not removable. Ceramic magnets only. Honing of the magnets or reforming the can will not be allowed. Only single-piece (two magnets in a can), or split (four magnets in a can) are allowed. Single piece magnets will not be cut to emulate split magnets. Single piece or split magnets must be of equal size and glued into the can in such a way that they do not advance the magnetic timing of the motor.
  - 8.8.4.3 Motor will have adjustable timing. Timing rings shall not be drilled to allow any increased timing other than those drill holes from the manufacturer. Timing for motors shall not exceed 36 degrees.
  - 8.8.4.4 Brush hoods will be stand up (3.75 mm x 5 mm) only. Brush hoods may be changed from approved ROAR can/ endbell combinations to allow for stand up brush hoods.
  - 8.8.4.5 "L" cut/ timed brushes will not be allowed. Only 3.75 mm x 5 mm brushes and hoods will be used. Trimming/ modifying or reducing the size of larger brushes to stand up brush size is not allowed. Slotting and/ or elongating the brush hoods mounting holes to cock/ shift the location or change the alignment of the brush is prohibited. Endbell must be secured to the can with screws. No gluing of the endbell to the can is allowed.
  - 8.8.4.6 Ball bearings are allowed.
  - 8.8.4.7 End bell must have the original manufacturer's logo, name or mark molded in.
  - 8.8.4.8 Swapping of components from one Manufacturer into a motor from another Manufacturer is prohibited. All 19T Oval motor combinations (armature/ can/ endbell) shall be manufacturer specific (i.e. Epic/ Epic/ Epic, Yokomo/ Yokomo/ Yokomo, etc.).

## 8.9 ELECTRIC VEHICLE CLASS SPECIFICATIONS

### 8.9.1 1/10 scale Electric Off-road Buggy (IFMAR Classes)

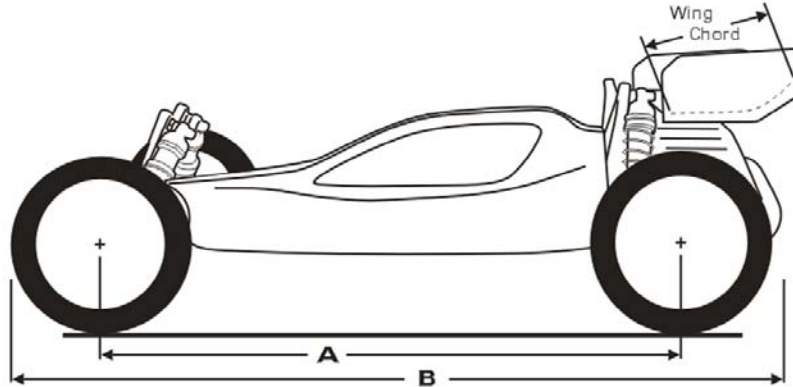

#### 8.9.1.1 Dimensional specifications:

Item		Limit	Specification
Length (B)		Maximum	457.2 mm
Width		Maximum	250 mm
Height		Maximum	203.2 mm
Wheelbase (A)		Maximum	292 mm
		Minimum	229 mm
Weight – six cell	2WD class	Minimum	1499g
	4WD class		1613g
Wheels	Mounting bead diameter	Maximum	55.88 mm
		Minimum	41.275 mm
	Overall diameter	Maximum	61.468 mm
	Width	Maximum	38.1 mm
Tires	Diameter	Maximum	90 mm
	Width	Maximum	44.45 mm
Rear Wing	Chord	Maximum	76.2 mm
	Side dam length	Maximum	100 mm
	Side dam height	Maximum	50 mm
	Width	Maximum	177 mm
Front Wing	Chord	Maximum	63.5 mm
	Side dam length	Maximum	69.85 mm
	Side dam height	Maximum	19.05 mm
	Width	Maximum	127 mm

8.9.1.2 Tire type: Rubber only

8.9.1.3 Battery Cells: Six cell maximum.

8.9.1.4 Transmission: Single speed transmissions only

8.9.1.5 Rear suspension: Independent.

8.9.1.6 Body Style: Buggy or other off-road style body that resembles an actual off-road racing non-truck type vehicle.

## 8.9.2 1/10 scale Electric Off-road Truck:

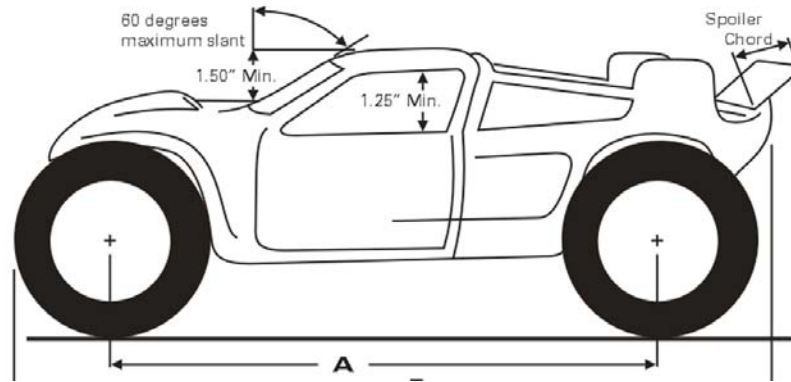

### 8.9.2.1 Dimensional specifications:

Item		Limit	Specification
Length (B)		Maximum	18.0"
		Minimum	15.25"
Width		Maximum	13.0"
		Minimum	9.0"
Wheelbase (A)		Maximum	11.5"
		Minimum	9.0"
Weight	2WD class	Minimum	60 ounces
	4WD class		64 ounces
Wheels	Mounting bead diameter	Maximum	2.25"
		Minimum	2.175"
	Overall diameter	Maximum	2.46"
	Width	Maximum	2.0"
Tires	Diameter	Minimum	3.6"
	Width	Maximum	2.125"
		Minimum	2.0"
Spoiler	Chord	Maximum	2.0"
	Width	Maximum	Body width
	Edge turn-up	Maximum	0.25"
Body	Width	Minimum	5.75"
	Height	Minimum	4.25"
Cab	Width	Minimum	3.875"
	Height	Minimum	1.50
Window	Height	Minimum	1.25"
	Slant	Maximum	60 degrees
Frontal Area	See 8.7.2.2 below	Minimum	23.03 sq. inches

### 8.9.2.2 Formula for Frontal area calculation:

$\text{Cab width} + \text{body width} / 2 \times \text{cab height} + \text{body width} \times \text{body height}$ .

### 8.9.2.3 Tire type: Rubber only

### 8.9.2.4 Battery Cells: Six cell maximum.

### 8.9.2.5 Transmission: Single speed transmissions only

### 8.9.2.6 Rear suspension: Independent.

### 8.9.2.7 Body Style: Off-road Truck

### 8.9.2.8 Wheel arch cut-outs: To molded body line

### 8.9.3 1/12 Scale Electric On-Road (IFMAR Class):

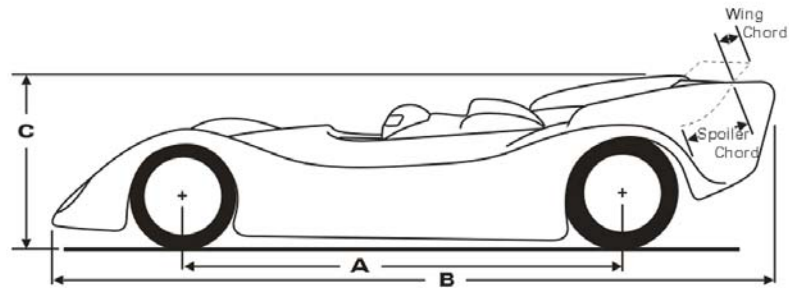

#### 8.9.3.1 Dimensional Specifications

Item		Limit	Specification
Length (B)		Maximum	380 mm
		Minimum	320 mm
Width	Chassis	Maximum	172mm
	Body	Maximum	174mm
Height (C)		Minimum	70 mm
Wheelbase (A)		Maximum	222 mm
		Minimum	184 mm
Weight		Minimum	794 g
Wheels	Diameter	Maximum	38 mm
		Minimum	29 mm
	Width	Maximum	38 mm
		Minimum	13 mm
Tires	Width	Maximum	38 mm
		Minimum	13 mm
Rear Spoiler	Chord	Maximum	52mm
	Width	Maximum	172 mm

8.9.3.2 Tire type: Foam only

8.9.3.3 Battery Cells:

- Carpet surfaces: 4 cells maximum

8.9.3.4 Transmission: Single speed only

8.9.3.5 Rear suspension and drive:

- Single, one-piece drive axle only
- No independent suspension allowed.

8.9.3.6 Body style: Can-Am, GTP and WSC

8.9.3.7 Wheel arch cut-outs: Maximum 10 mm over tire diameter

8.9.3.8 Ground clearance:

- Carpet surfaces: Minimum 3mm under all parts of the vehicle excluding the spur gear.

### 8.9.4 1/10 Scale Electric On-road:

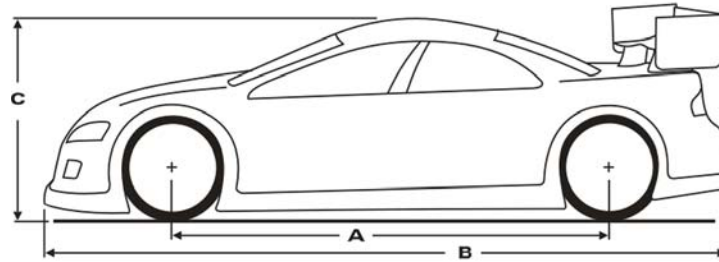
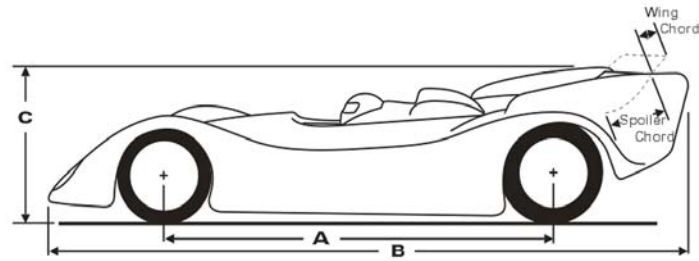

#### 8.9.4.1 Dimensional Specifications:

Item		Limit	Specification	
			Can-Am/GTP/WSC	GT/GT-1/Trans-Am
Length (B)		Maximum	22.05"	
Width		Maximum	9.875"	
Height (C)		Minimum	3.0"	4.0"
Wheelbase (A)		Maximum	11.0"	
		Minimum	9.0"	
Weight		Minimum	42.3 ounces	
Wheels	Diameter	Maximum	2.0"	
		Minimum	1.625"	
	Width	Maximum	2.0"	
		Minimum	0.75"	
Tires	Diameter	Maximum	2.6"	
	Width	Maximum	2.0"	
		Minimum	0.75"	
Rear Spoiler	Chord	Maximum	2"	
	Width	Maximum	9.875"	
Rear Wing (if fitted to the full-size vehicle)	Chord	Maximum	Not allowed	3.0"
	Width	Maximum	Not allowed	9.0"
	Side dam length	Maximum	Not allowed	3.0"
	Side dam height	Maximum	Not allowed	3.75"

8.9.4.2 Tire type: Foam only

8.9.4.3 Battery Cells: 6 cells maximum

8.9.4.4 Transmission: Single speed only

8.9.4.5 Rear suspension and drive:

- Single, one-piece drive axle only
- No independent suspension allowed.

8.9.4.6 Body style: Can-Am/GTP/WSC or GT/GT-1/Trans-Am

8.9.4.7 Wheel arch cut-outs: Maximum 0.375" over tire diameter

8.9.4.8 Ground clearance

- Minimum 4 mm under all parts of the vehicle excluding the spur gear.

### 8.9.5 1/10 Scale Electric On-road T-2 Touring Car (IFMAR ISTC Class):

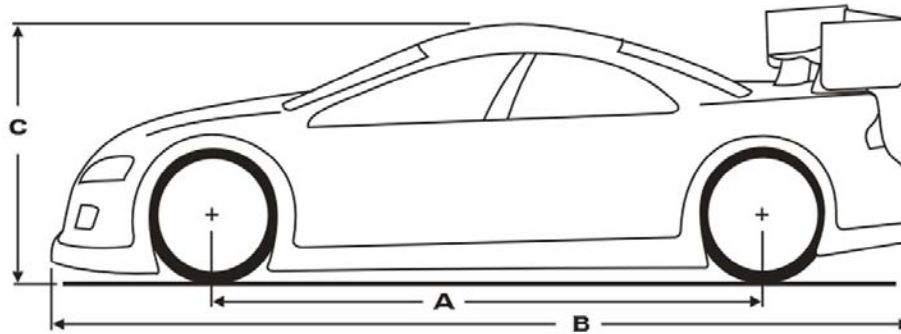

#### 8.9.5.1 Dimensional Specifications

Item		Limit	Specification
Length (B)		Maximum	460 mm
Width (see Note 1)	With body	Maximum	195mm
	Without body	Maximum	190 mm
Height (C) (with 20mm blocks under chassis)		Maximum	190 mm
		Minimum	130 mm
Wheelbase (A)		Maximum	270 mm
		Minimum	250 mm
Weight – six cell		Minimum – Foam	1418 g
		Minimum – Rubber	1525 g
Wheels	Diameter	Maximum – Foam	53 mm
		Maximum – Rubber	50 mm
		Minimum	47 mm
	Width	Maximum - Foam	31 mm
		Maximum - Rubber	26 mm
Minimum		24 mm	
Tires	Diameter	Maximum – all types	67 mm
		Minimum – Rubber only	63 mm
	Width	Maximum - Foam	31 mm
		Maximum - Rubber	28 mm
		Minimum	24 mm
Rear Wing (see 8.9.5.8 below)	Chord	Maximum	40 mm
	Width	Maximum	190 mm
	Side dam length	Maximum	40 mm
	Side dam height	Maximum	20 mm

**Note 1:** Vehicles must comply with both specifications during a single inspection.

#### 8.9.5.2 Tire type:

- Carpet surfaces: Foam only or Rubber only (no mixing of tire types in a single event)
- Paved Surfaces: Rubber only
- Capped tires are not allowed on any surface.

8.9.5.3 Battery Cells: Six cell maximum.

8.9.5.4 Transmission: Single speed only

8.9.5.5 Front and Rear suspension: Independent.

8.9.5.6 Drive: 4WD only.



#### 8.9.5.7 Body rules:

- Bodies must resemble 2 or 4 door cars that have raced in a Touring Car series. See Global Body Specifications below.
- Wheel arch cut-outs: Maximum 9.5 mm over tire diameter
- The rear of the body may not be cut higher than 55mm above the measuring surface with the chassis resting on 20mm blocks.
- No windows may be cut out.

#### 8.9.5.8 Wing rules:

- Only one wing is allowed, fixed to the same place as the wing on the full-size vehicle.
- The wing must be fastened to the rear deck of the body, not directly to any part of the chassis of the vehicle.
- The rear edge of the wing or side dams may not extend beyond the rear of the body more than 10 mm.
- No part of the wing may extend above the roofline of the body.

#### 8.9.5.9 Ground clearance:

- Carpet surfaces: Minimum 4 mm for foam tires and 5mm for rubber tires under all parts of the vehicle excluding the spur gear.

### **\*\* GLOBAL BODY SPECIFICATIONS \*\***

Bodies submitted for approval after January 1, 2007 must conform to the following dimensions illustrated in these diagrams. All previously approved bodies will require a complimentary resubmittal if no changes are necessary to compete after January 1, 2008.

## GLOBAL BODY SPEC ( GBS for Electric Sedans )

(A) = Max 10 mm

(B) = Min 105 mm

(C) = Max 85 mm

(D) = Min 90 mm

(E) = Min 65 mm

(F) = Max 65 mm

(G) = Max 25 mm ( Max 3 posts )

(H) = Min 410 mm

(I) = Min 170 mm

(J) = Min 35 mm

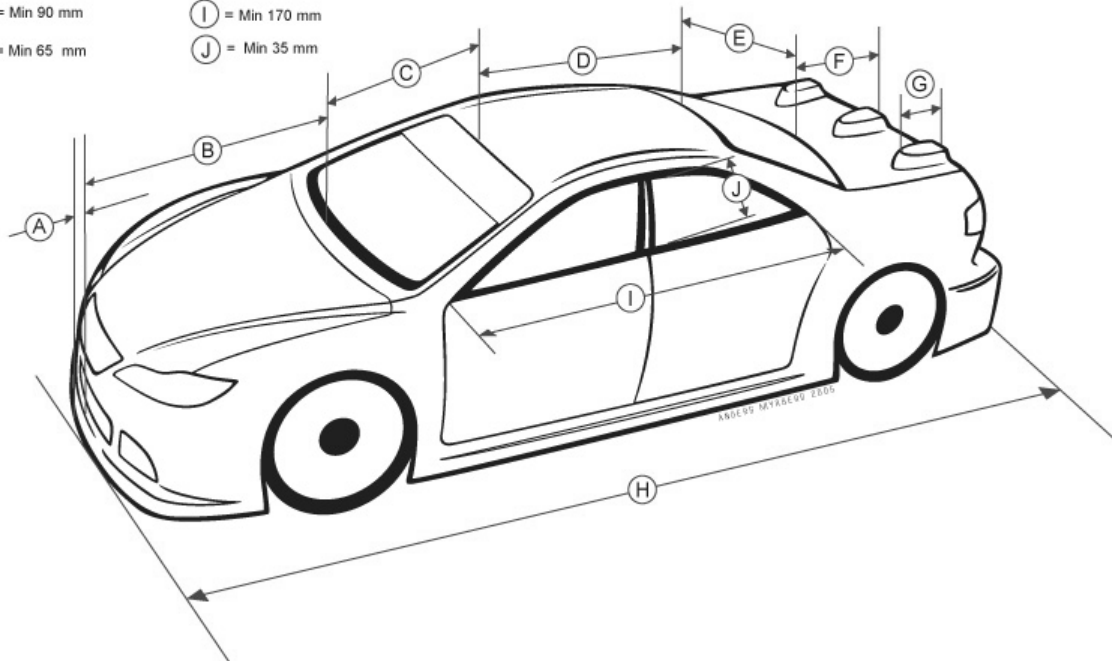

# GLOBAL BODY SPEC ( GBS for Electric Sedans )

- (K) = Min 140 mm Max 155 mm
- (L) = Min 110 mm Max 125 mm
- (M) = Min 115 mm
- (N) = Max 195 mm

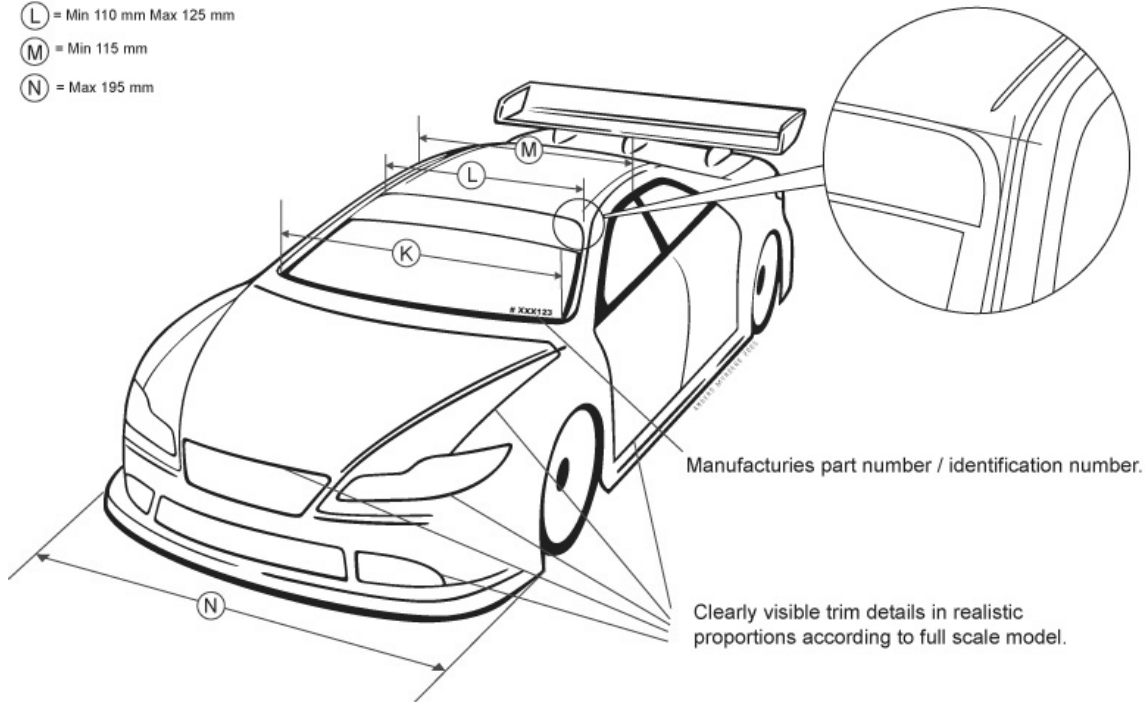

# GLOBAL BODY SPEC ( GBS for Electric Sedans )

- (O) = Min 150 mm
- (P) = Min 95 mm
- (Q) = Max 10 mm
- (R) = Min 115 mm
- (S) = Max 35 mm

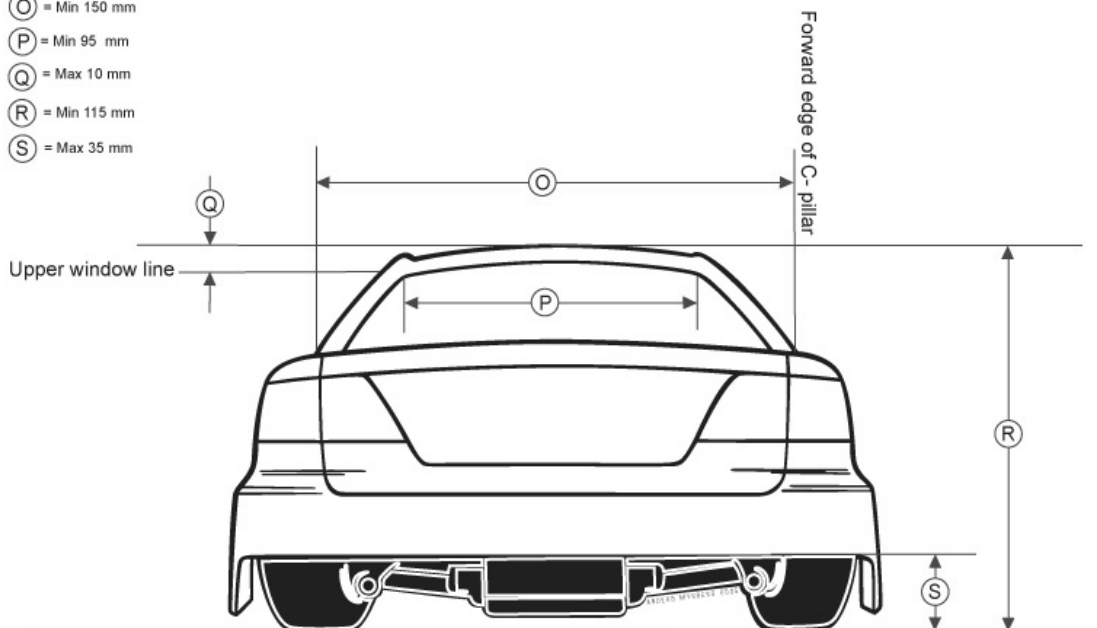

### 8.9.6 1/10 Scale Electric On-road CART/IRL/Formula 1:

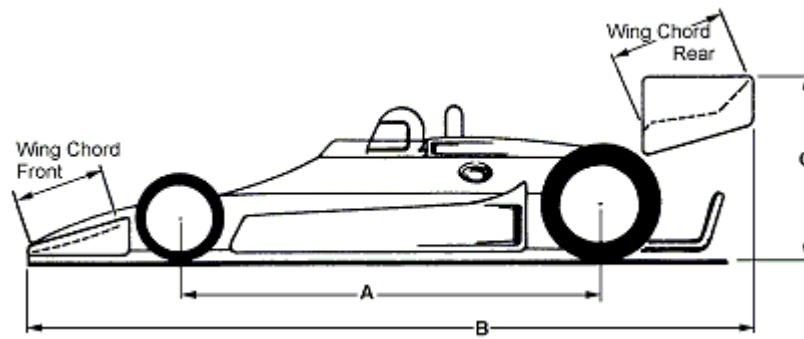

#### 8.9.6.1 Dimensional Specifications:

Item		Limit	Specification
Length (B)		Maximum	22.0"
Width		Maximum	8.4"
Height (C)		Maximum	5.5"
Wheelbase (A)		Maximum	11.0"
		Minimum	9.0"
Weight		Minimum	36 ounces
Wheels	Diameter	Maximum	1.42"
		Minimum	1.25"
	Width	Maximum	1.75"
		Minimum	0.75"
Tires	Diameter	Maximum	2.5"
		Minimum	1.5"
	Width	Maximum	1.75"
		Minimum	0.75"
	Width	Maximum	9.875"
	Front Wing	Chord	Maximum
Width		Maximum	9.0"
Side dam length		Maximum	2.5"
Side dam height		Maximum	1.5"
Rear Wing	Chord	Maximum	3.0"
	Width	Maximum	9.0"
	Side dam length	Maximum	3.75"
	Side dam height	Maximum	2.0"

8.9.6.2 Tire type: Foam only

8.9.6.3 Battery Cells:

- 6 cells maximum
- Stick or side-by-side packs only. No saddle packs are allowed

8.9.6.4 Transmission: Single speed only

8.9.6.5 Rear suspension and drive:

- Single, one-piece drive axle only
- No independent suspension allowed.

8.9.6.6 Body style: Bodies must resemble open wheel, single seat cars used in CART, IRL, Formula One or other similar full-size series.

## 8.9.7 1/12 Scale Electric Oval:

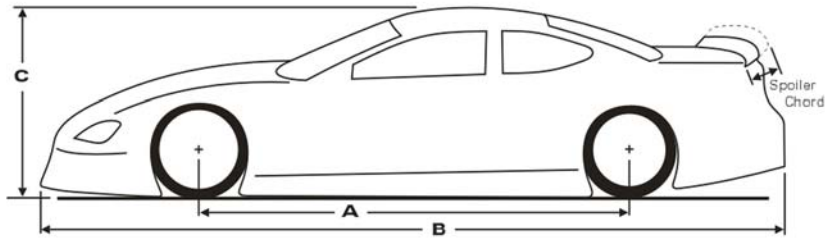

### 8.9.7.1 Dimensional specifications:

Item		Limit	Specification
Length (B)		Maximum	16.0"
Width		Maximum	7.0"
Height (C)	Foam Tires	Minimum	3.375"
	Capped Tires	Minimum	3.5"
Wheelbase (A)		Maximum	9.25"
		Minimum	7.25"
Weight	Foam Tires	Minimum	33 ounces
	Capped Tires	Minimum	35 ounces
Wheels	Diameter	Maximum	1.5"
		Minimum	1.3"
	Width	Maximum	1.5"
		Minimum	0.5"
Tires	Diameter	Maximum	2.1"
	Width	Maximum	1.5"
		Minimum	0.5"
Rear Wing	Chord	Maximum	2.0"
	Width	Maximum	6.75"
	Side dam length	Maximum	2.5"
	Side dam height	Maximum	1.75"
Rear Spoiler	Chord – with wing	Maximum	0.5"
	Chord – without wing	Maximum	1.5"
	Width	Maximum	6.75"

### 8.9.7.2 Tire type:

- Foam or Capped

### 8.9.7.3 Battery Cells:

- 4 cells maximum

### 8.9.7.4 Transmission: Single speed only

### 8.9.7.5 Rear suspension and drive:

- Single, one-piece drive axle only
- No independent suspension allowed.

### 8.9.7.6 Body style: Bodies must resemble NASCAR-type stock cars.

### 8.9.7.7 Wheel arch cut-outs: Maximum 0.375" over tire diameter

### 8.9.7.8 Ground clearance:

- Carpet surfaces: Minimum 0.125" under all parts of the vehicle excluding the spur gear.

### 8.9.8 1/10 Scale Electric Oval:

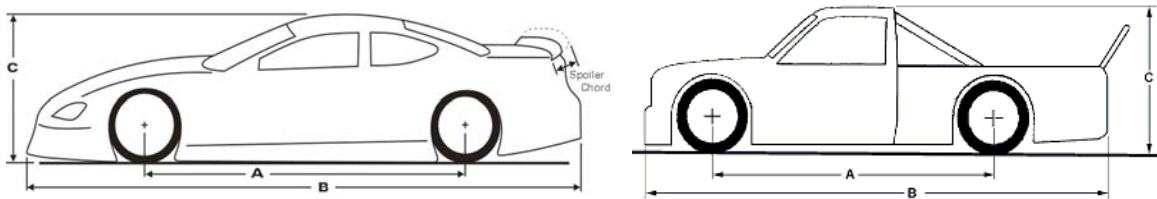

#### 8.9.8.1 Dimensional specifications:

Item		Limit	Specification	
			Car	Truck
Length (B)		Maximum	20.0"	
Width		Maximum	9.875"	
		Minimum	7.25"	
Height (C)	Foam Tires	Minimum	4.25"	4.5"
	Capped Tires	Minimum	4.5"	4.75"
Wheelbase (A)		Maximum	11.0"	
		Minimum	9.0"	
Weight – 6 cell	Foam Tires	Minimum	43 ounces	
	Capped Tires	Minimum	45 ounces	
Weight – 4 cell	Foam Tires	Minimum	41 ounces	
	Capped Tires	Minimum	43 ounces	
Wheels	Diameter	Maximum	2.0"	
		Minimum	1.625"	
	Width	Maximum	2.0"	
		Minimum	0.75"	
Tires	Diameter	Maximum	2.6"	
		Maximum	2.0"	
		Minimum	0.75"	
Rear Wing	Chord	Maximum	3.0"	Not allowed
	Width	Maximum	9.0"	Not allowed
	Side dam length	Maximum	3.75"	Not allowed
	Side dam height	Maximum	2.0"	N/A
Rear Spoiler	Chord - with wing	Maximum	0.75"	N/A
	Chord - no wing	Maximum	2.0"	2.0"
	Width	Maximum	9.875"	9.875"

8.9.8.2 Tire type: Foam or Capped

8.9.8.3 Battery Cells: Six cells maximum

8.9.8.4 Transmission: Single speed only

8.9.8.5 Rear suspension and drive:

- Single, one-piece drive axle only
- No independent suspension allowed.

8.9.8.6 Body rules:

- Bodies must resemble NASCAR-type stock cars or trucks.
- On truck bodies the tailgate section may be removed, but the side panels must remain intact.
- The truck box must be covered flush with the top of the box, and must be painted.
- Wings and/or side dams are not allowed on trucks.

8.9.8.7 Wheel arch cut-outs: Maximum 0.5" over tire diameter

8.9.8.8 Ground clearance: Minimum pre-race is 0.1875

8.9.9 1/10 Scale Electric Dirt Oval:

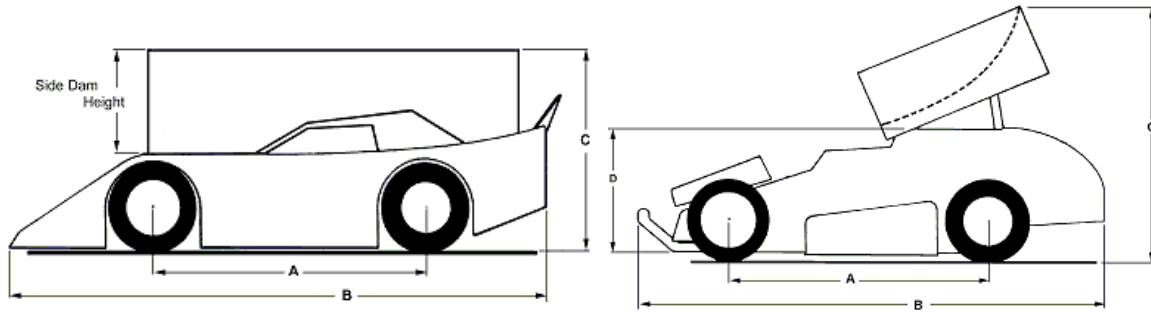

8.9.9.1 Dimensional specifications:

Item		Limit	Specification	
			Modified Stock Car	Sprint Car
Length (B)		Maximum	22.0"	18.0"
Width		Maximum	9.875"	
Height (C)		Maximum	11.0"	
Wheelbase (A)		Maximum	11.5"	
		Minimum	9.0"	10.0"
Weight – 2WD	2WD	Minimum	50 ounces	
	4WD	Minimum	52 ounces	
	Truck	Minimum	50 ounces	
Wheels	Diameter	Maximum	2.15"	
		Minimum	1.5"	
	Width	Maximum	2.0"	
Tires	Diameter	Maximum	3.544"	
	Width	Maximum	2.0"	
Rear wing and/or side dam	Chord	Maximum	N/A	7.0"
	Width	Maximum		6.0"
	Side dam length	Maximum	14.0"	7.0"
	Side dam height	Maximum	5.5"	4.0" above wing surface
Front wing	Chord	Maximum	N/A	2.0"
	Width	Maximum		4.0"
	Side dam length	Maximum		2.0
	Side dam height	Maximum		1.0 above wing surface
Rear Spoiler	Chord	Maximum	1.5"	N/A
	Width	Maximum	9.875"	

8.9.9.2 Tire type: Foam, Rubber or Capped

8.9.9.3 Battery Cells: Six cells maximum

8.9.9.4 Transmission: Single speed only

8.9.9.5 Rear suspension and drive:

- Independent
- 2WD or 4WD

8.9.9.6 Body rules:

- Bodies must resemble NASCAR-type stock cars or trucks, modified Stock Cars, Sprint Cars or Off-road trucks.
- Sprint cars must have headers, nerf bars, rear tail section, and roll cage

8.9.9.7 Wheel arch cut-outs: Maximum 0.5" over tire diameter

## 9 “NITRO” FUEL CLASS RULES

The following rules are additional rules for nitro-fueled vehicles. In most cases, the rules in this section are designed to further define the General Rules. At no time are these rules to be used without regard to the General Rules, which apply to all vehicle types and classes.

### 9.1 FUEL SPECIFICATIONS

- 9.1.1 Fuels may contain only methanol, nitro methane, coloring agent, and a lubricant.
- 9.1.2 The following additives are specifically prohibited: hydrazine, hydrogen peroxide, propylene oxide, and toluene.

### 9.2 GENERAL VEHICLE SPECIFICATIONS

- 9.2.1 All fuel-powered vehicles must be equipped with a working brake system capable of stopping the vehicle and holding it motionless with the engine running.
- 9.2.2 All vehicles must be equipped with a working de-clutching device capable of allowing the vehicle to stand stationary with the engine running.
- 9.2.3 Any event official may check engines, fuel tank capacities, carburetors, and other specifications at any time.

#### 9.2.4 EXHAUST RULES:

- 9.2.4.1 All vehicles are required to use a muffler or tuned pipe through which the exhaust gas must pass.
- 9.2.4.2 A ROAR or IFMAR approved muffler or tuned pipe must be used in all ROAR-sanctioned events.
- 9.2.4.3 Exhaust discharge must be parallel to the ground or lower.
- 9.2.4.4 The maximum allowable sound level is 85 decibels, measured at ninety degrees to the direction of travel of the vehicle from a distance of 33 feet; 3 feet above the ground, with the vehicle at maximum throttle and at all speeds. A Radio Shack sound meter (Part #33-2055) or equivalent should be used to check the sound level.
- 9.2.4.5 Any vehicle that loses its muffler will be black-flagged and not scored until repaired.
- 9.2.4.6 The muffler or tuned pipe outlet must have a single, round, constant inside diameter, with its end cut at 90 degrees to its centerline. The inner diameter of the exhaust outlet must be circular within the maximum size specified in the table. Oval or misshapen stingers that may not accept a plug gauge of the specified size but measure oversize using other measurement devices are not permitted.
- 9.2.4.7 Muffler dimensions are specified according to engine size, as follows:

Exhaust Outlet Specification	.12 ROAR/ IFMAR	.12 OPEN	.15 ROAR/ IFMAR	.15 OPEN	.21OPEN
Maximum inner diameter (9.2.4.6)	5.0mm	5.2mm	5.2mm	6.5mm	8.0mm
Minimum length	15.0mm	15.0mm	15.0mm	15.0mm	15.0mm

#### 9.2.5 DRIVE AND TRANSMISSION SPECIFICATIONS:

- 9.2.5.1 All gearboxes must be on a single shaft. Multiple-speed transmissions are allowed for some on-road classes (see vehicle specifications), but not for off-road racing except for the Monster Truck class. Automatic or variable overdrive systems are not allowed.
- 9.2.5.2 Hydraulic or viscous drive systems are not allowed.
- 9.2.6 Antennas must be flexible. “Roll-over” antennas are not permitted in any fuel class.

#### 9.2.7 SAFETY SPECIFICATIONS:

- 9.2.7.1 In case of linkage failure, cars must incorporate a positive action return device attached directly to the carburetor throttle arm to provide positive closure.

**9.2.8 FUEL TANK SPECIFICATIONS:**

- 9.2.8.1 Fuel tanks must be securely mounted.
- 9.2.8.2 Maximum fuel system capacities are 75cc for .12 engines, 80cc for .15 engines, and 125cc for .21 engines.
- 9.2.8.3 There are two approved ways to determine the fuel capacity of a vehicle. The first way is by pouring the correct amount into the vehicle's system, and the second way pumps the fuel out of the vehicle's system into a measurement container. The Race Director must ensure that all waste fuel is disposed of properly.
- 9.2.8.3.1 To check a tank capacity the first way, drain all fuel from the system including fuel and pressure lines. Pinch off the pressure line at the tank, and disconnect the fuel line from the carburetor. Using a graduated cylinder, measure the proper amount of the driver's fuel. The graduated cylinder is read at the bottom of the fuel's meniscus when viewed from the side of the cylinder at eye level. Pour the fuel into the tank, allowing fuel line and filter (if fitted) to fill. The fuel should fill the tank to the top of the filler neck, or to a point where fuel overflows or is forced out when the lid is closed. If it does not, the tank is oversized and a fixed insert must be used to reduce the tank capacity.
- 9.2.8.3.2 To check the tank capacity the second way, fill the tank to the top of the filler neck. Make sure all fuel lines are full. Attach a fuel pump or large capacity syringe to the end of the tank-to-engine fuel line. Transfer the fuel completely out of the vehicle's system into a graduated cylinder or another accurate liquid measuring device. (Reading a graduated cylinder is described above, in this rule.) If there is more fuel retrieved than allowed, the tank is oversized and a fixed insert must be used to reduce the tank capacity.
- 9.2.8.3.3 A 10 minute cool down period may be allowed for tanks close to the limit (less than 3cc). This decision can only be made by the ROAR Official or Race Director.

**9.3 ENGINE SPECIFICATIONS**

- 9.3.1 Only single-cylinder, two-stroke, normally aspirated, air-cooled, glow-ignition engines utilizing standard or turbo plugs are permitted in ROAR-sanctioned events.
- 9.3.2 No forced aspiration systems, liquid cooling systems or fuel pressurization systems (other than by means of exhaust pressure applied directly to the vehicle's fuel tank) are allowed.
- 9.3.3 Any carburetor may be used as long as the bore does not exceed the maximum allowable for the engine size. Restrictors may be used to achieve the legal diameter, but must be securely fastened in place.
- 9.3.4 Other than in the bearings, ceramic parts are not allowed in any engine raced in ROAR-sanctioned events.
- 9.3.5 Engine dimensions/requirements for ROAR legal engines:

<b>Engine Type</b>	<b>Maximum displacement</b>	<b>Maximum carburetor bore (see Note 1)</b>
<b>.12 ROAR/IFMAR</b>	.129ci - 2.11cc	5.5mm
.12 OPEN	.129ci - 2.11cc	5.5mm
<b>.15 OPEN</b>	.152ci - 2.50cc	7.0mm
.21 OPEN	.214ci - 3.50cc	9.0mm
<b>.28 OPEN</b>	.284ci - 4.66cc	9.0mm

**NOTE 1:** Measured directly above the spray bar or needle of the carburetor.

- 9.3.6 For .12 ROAR/IFMAR class engines the maximum number of ports including the exhaust port is FOUR.



## 9.4 FUEL VEHICLE CLASS SPECIFICATIONS

### 9.4.1 1/10 Scale Fuel Off-road:

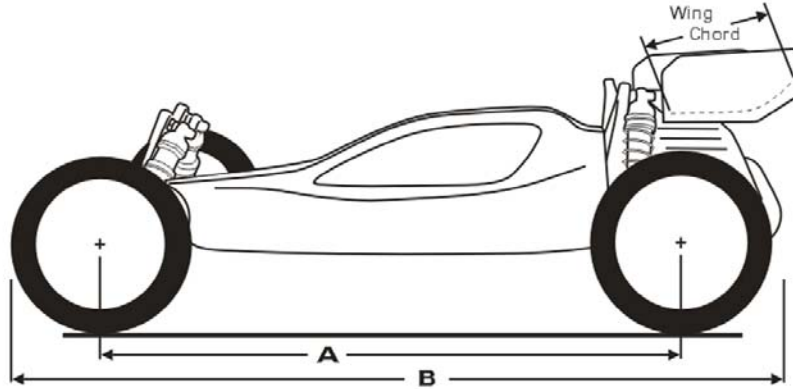

#### 9.4.1.1 Dimensional specifications:

Item		Limit	Specification
Length (B)		Maximum	18.0"
Width		Maximum	9.875"
Wheelbase (A)		Maximum	11.5"
		Minimum	9.0"
Weight	2WD class	Minimum	56 ounces
	4WD class		60 ounces
Wheels	Mounting bead diameter	Maximum	2.2"
		Minimum	1.625"
	Overall diameter	Maximum	2.42"
	Width	Maximum	1.5"
Tires	Diameter	Maximum	3.544"
	Width	Maximum	1.75"
Rear Wing	Chord	Maximum	3.0"
	Side dam length	Maximum	3.937"
	Side dam height	Maximum	2.0"
	Width	Maximum	7.0"
Front Wing	Chord	Maximum	2.5"
	Side dam length	Maximum	2.75"
	Side dam height	Maximum	0.75"
	Width	Maximum	5.0"

9.4.1.2 Tire type: Rubber only

9.4.1.3 Engine size: .12 Open

9.4.1.4 Transmission: Single speed transmissions only

9.4.1.5 Rear suspension: Independent.

9.4.1.6 Body Style: Buggy or other off-road style body that resembles an actual off-road racing non-truck type vehicle.

#### 9.4.2 1/10 Scale Fuel Off-road Truck:

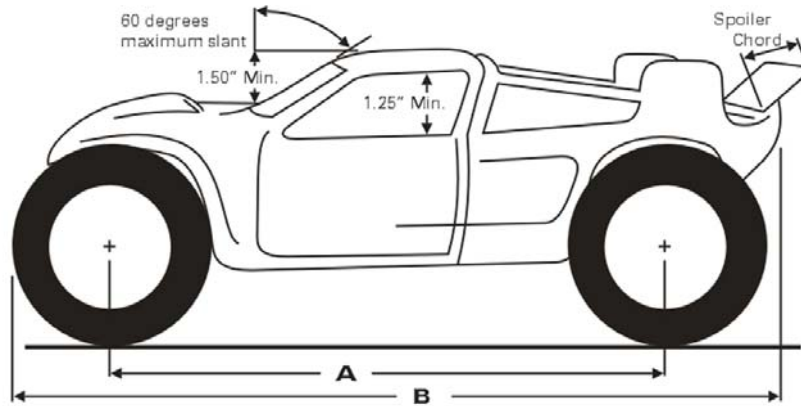

##### 9.4.2.1 Dimensional specifications:

Item		Limit	Specification
Length (B)		Maximum	18.0"
Width		Maximum	13.0"
Wheelbase (A)		Maximum	11.5"
		Minimum	9.0"
Weight	2WD class	Minimum	60 ounces
	4WD class		64 ounces
Wheels	Mounting bead diameter	Maximum	2.25"
		Minimum	2.175"
	Overall diameter	Maximum	2.46"
	Width	Maximum	2.0"
Tires	Diameter	Minimum	3.6"
	Width	Maximum	2.125"
		Minimum	2.0"
Spoiler	Chord	Maximum	2.0"
	Width	Maximum	Body width
	Edge turn-up	Maximum	0.25"
Body	Width	Minimum	5.75"
	Height	Minimum	4.25"
Cab	Width	Minimum	3.875"
	Height	Minimum	1.50
Window	Height	Minimum	1.25"
	Slant	Maximum	60 degrees
Frontal Area	See 8.7.2.2 below	Minimum	23.03 sq. inches

##### 9.4.2.2 Formula for Frontal area calculation:

$\text{Cab width} + \text{body width} / 2 \times \text{cab height} + \text{body width} \times \text{body height}.$

##### 9.4.2.3 Tire type: Rubber only

##### 9.4.2.4 Engine size: .12 Open

##### 9.4.2.5 Transmission: Single speed transmissions only

##### 9.4.2.6 Rear suspension: Independent.

##### 9.4.2.7 Body Style: Off-road Truck

##### 9.4.2.8 Wheel arch cut-outs: To molded body line

9.4.3 **1/8 Scale Fuel Off-road (IFMAR Class):**

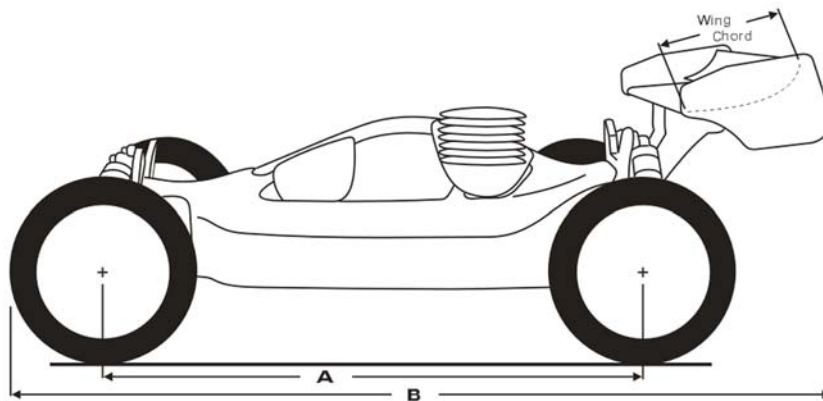

9.4.3.1 Dimensional specifications:

Item		Limit	Specification
Length (B)		Maximum	730 mm
Width		Maximum	310 mm
Height (measured with suspension fully compressed)		Maximum	250 mm
Wheelbase (A)		Maximum	330 mm
		Minimum	270 mm
Weight		Minimum	3200 g
Wheels	Overall diameter	Maximum	86.36 mm
		Minimum	81.28 mm
	Width	Maximum	44.45 mm
Tires	Diameter	Maximum	119.38 mm
		Minimum	109.22 mm
	Width	Maximum	46.99 mm
Rear Wing	Side dam length	Maximum	92.07 mm
	Side dam height	Maximum	60.33 mm
	Chord	Maximum	77 mm
	Width	Maximum	217 mm

9.4.3.2 Tire type: Rubber only

9.4.3.3 Engine size: .21 Open

9.4.3.4 Transmission and drive:

- Single speed transmissions only
- 2WD or 4WD

9.4.3.5 Rear suspension: Independent.

9.4.3.6 Body Style: Buggy or other off-road style body that resembles an actual off-road racing non-truck type vehicle.



#### 9.4.4 Fuel Off-road Monster Truck:

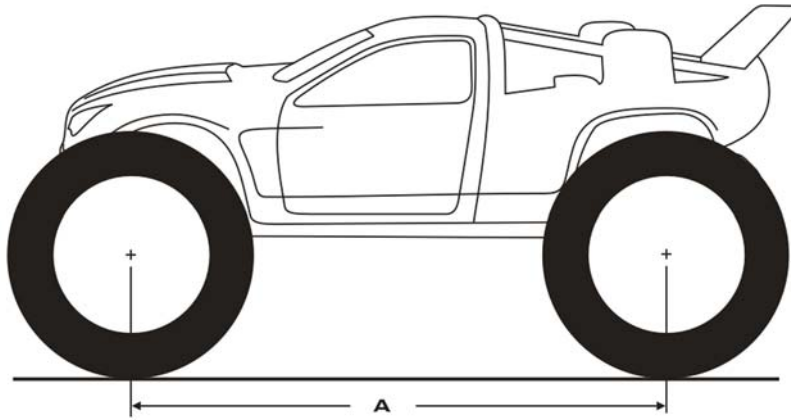

##### 9.4.4.1 Dimensional specifications:

Item		Limit	Specification		
			Monster Truck		1/8 Truck
Engines (all OPEN, see 9.3)			.12 - .20	.21 - .28	.12 - .28
Wheelbase (A)		Minimum	12.0"		
Weight		Minimum	96 oz.	152 oz.	144 oz (9 lbs)
		Maximum	13 lbs. 6 oz		
Tires (mounted)	Diameter	Minimum	5.10"		4.55"
	Width	Minimum	2.75"		2.25"
Fuel tank capacity		Maximum	150 cc	175cc	150 cc
Rear Wing	Side dam length	Maximum	92.07 mm		
	Side dam height	Maximum	60.33 mm		
	Chord	Maximum	77 mm		
	Width	Maximum	217 mm		

9.4.4.2 Monster Trucks are defined by fully compressing the vehicle's suspension and measuring a minimum of 1.5" from the flat surface to the underside of the engine. Two or three speed gear reduction transmissions are required. Differentials residing inside the transmission are permitted. All reverse gearing must be disabled for racing.

9.4.4.3 All Monster Trucks will race together unless sufficient entries warrant splitting the entrants according to the specifications in the above table.

9.4.4.4 1/8 Trucks are all trucks which do not comply with rule 9.4.4.2 but satisfy the specifications in the above table and the general Monster Truck rules.

9.4.4.5 Deleted in 2006

9.4.4.6 Drive configuration: Two or four wheel drive is allowed.

9.4.4.7 Tire rules

9.4.4.7.1 No tires created for other vehicle types even if they meet the specifications will be allowed.

9.4.4.7.2 Cutting or modifying the tread is allowed. Modifying the tire carcass is prohibited (i.e. no "CUT" tires - whether they started as a Monster Truck tire or not). Trimming the mounting bead of a production Monster Truck tire in order to fit a legal rim is allowed.

9.4.4.7.3 All tire measurements reference the carcass dimensions and do not include the tread depth or width. *LP tires are referenced for the minimum 1/8 Truck size and measure the absolute minimal diameter allowable in the 1/8 Truck class.*

9.4.4.8 Bodies: Truck or SUV only (no buggy or car bodies allowed).

- 9.4.4.9 Bumpers are optional. If used, they may not extend further than 1" past the body, front or rear, and may not exceed the width across the outer edges of the tires to each side.
- 9.4.4.10 Rule incorporated into 9.4.4.1 dimensional specifications in 2007.
- 9.4.4.11 Skid Plates must not extend further than 1" past the body, front or rear. Metal skid plates and chassis components are only allowed if safely attached and pose no danger to drivers, pit persons, or turn marshals.
- 9.4.4.12 3 channel radios are permitted. Control is limited to throttle, brake, forward speed shifting, and steering.

9.4.5 1/10 Scale .15 Fuel On-road 2WD:

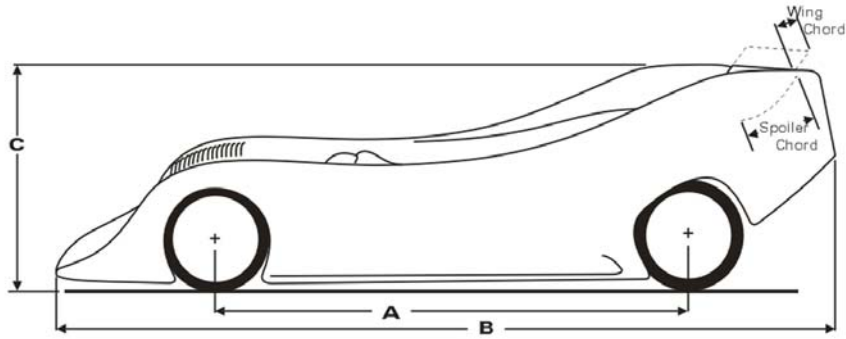

9.4.5.1 Dimensional Specifications:

Item		Limit	Specification
Length (B)		Maximum	19.0"
Width		Maximum	9.875"
Height (C)		Minimum	4.625"
Wheelbase (A)		Maximum	11.0"
		Minimum	9.0"
Weight	Suspension	Minimum	64 ounces
	Pan Chassis	Minimum	52 ounces
Wheels	Diameter	Maximum	2.125"
		Minimum	1.625"
	Width – Front	Maximum	1.18"
	Width - Rear	Maximum	2.0"
Tires	Diameter – Front	Maximum	3.0"
	Diameter - Rear	Maximum	3.2"
	Width – Front	Maximum	1.18"
	Width - rear	Maximum	2.0"
Rear Spoiler	Chord	Maximum	2.0"
	Width	Maximum	9.875"
Rear Wing	Chord	Maximum	3.0"
	Width	Maximum	9.0"
	Side dam length	Maximum	3.75"
	Side dam height	Maximum	2.0"

9.4.5.2 Tire type: Foam only

9.4.5.3 Engine size: .15 Open

9.4.5.4 Transmission: Single or two-speed

9.4.5.5 Rear suspension and drive:

- Single, one-piece drive axle only in Pan class
- Independent suspension allowed in Suspension class
- Rear Wheel drive only.

9.4.5.6 Body style: Can-Am/GTP/WSC

9.4.5.7 Wheel arch cut-outs: Maximum 0.5" over tire diameter

#### 9.4.6 1/10 Scale On-road 4WD Open:

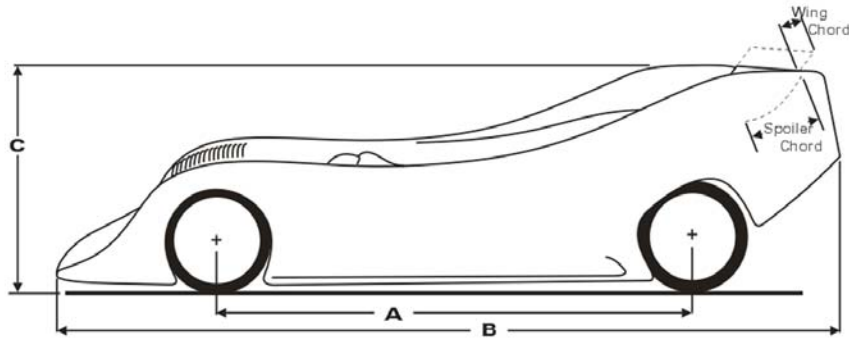

##### 9.4.6.1 Dimensional Specifications:

Item		Limit	Specification	
			235mm	200mm
Length (B)		Maximum	490 mm	460 mm
Width	without body	Maximum	250 mm	200 mm
	with body	Maximum	250 mm	205 mm
Height (C)		Maximum	150 mm	125 mm
Wheelbase (A)		Maximum	280 mm	270 mm
		Minimum	228 mm	230 mm
Weight		Minimum	2000 g	1725 g
Wheels	Diameter	Maximum	54 mm	51 mm
		Minimum	49 mm	47 mm
	Width - Front	Maximum	30 mm	31 mm
	Width - Rear	Maximum	50.8 mm	31 mm
Tires	Diameter - Front	Maximum	76.2 mm	67 mm
	Diameter - Rear	Maximum	81.3 mm	67 mm
	Width - Front	Maximum	30 mm	31 mm
	Width - Rear	Maximum	50.8 mm	31 mm
Rear Spoiler	Chord	Maximum	50.8 mm	50 mm
	Width	Maximum	250 mm	200 mm
Rear Wing	Chord	Maximum	76.2 mm	50 mm
	Width	Maximum	228 mm	200 mm
	Side dam length	Maximum	95.25 mm	50 mm
	Side dam height	Maximum	50.8 mm	35 mm

9.4.6.2 Tire type: Foam only

9.4.6.3 Engine size:

9.4.6.3.1 235mm: .15 ROAR/IFMAR or .15 Open

9.4.6.3.2 200mm: .12 ROAR/IFMAR or .12 Open

9.4.6.4 Transmission: Single or two-speed

9.4.6.5 Rear suspension and drive:

- Independent suspension allowed
- 4WD only

9.4.6.6 Body style:

- Any ROAR-approved body style. A specific style may be specified for Level 3-5 events.
- If Touring Car bodies are used, refer to the specifications in 9.4.7 or 9.4.8 below.

9.4.6.7 Wheel arch cut-outs: Maximum 10mm over tire diameter



9.4.7 1/10 Scale .12 On-road Fuel Touring Car 4WD (IFMAR class):

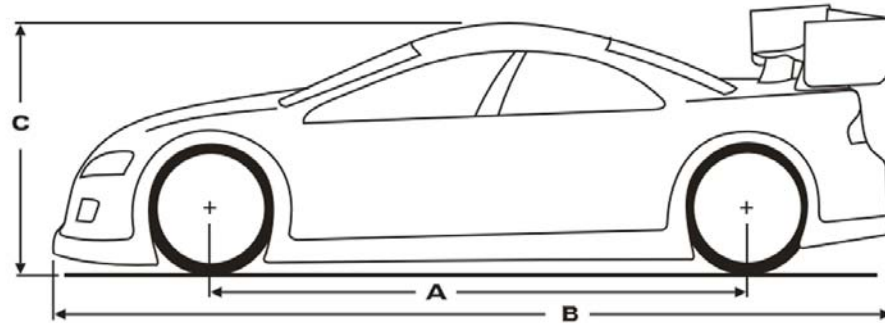

9.4.7.1 Dimensional Specifications:

Item		Limit	Specification
Length (B)		Maximum	460 mm
Width	Without Body (excluding stinger)	Maximum	200 mm
	With Body (including stinger)	Maximum	205mm
Height (C) (with 20mm blocks under chassis)		Minimum	130 mm
Wheelbase (A)		Maximum	270 mm
		Minimum	230 mm
Weight		Minimum	1725 g
Wheels	Diameter	Minimum	46 mm
	Width	Maximum	31 mm
Tires	Width	Maximum	31 mm
Rear Wing	Chord	Maximum	50 mm
	Width	Maximum	200 mm
	Side dam length	Maximum	50 mm
	Side dam height	Maximum	35 mm

9.4.7.2 Tire type: Foam or Rubber only. No capped tires allowed.

9.4.7.3 Engine size: .12 ROAR/IFMAR only

9.4.7.4 Transmission: Single or two-speed

9.4.7.5 Rear suspension and drive:

- Independent suspension allowed
- 4WD only

9.4.7.6 Body and Wing rules:

- Bodies must resemble a 2 or 4-door vehicle that has run in a full-size Touring Car series.
- Only one wing allowed; fitted in the same place as the wing on the original vehicle
- The wing must be fastened to the rear deck of the body, not to the chassis of the vehicle
- No part of the wing may extend above the roofline of the body.
- The rear of the body may not be cut out higher than 55mm above the ground, measured with the chassis resting on 20mm high blocks.

9.4.7.7 Wheel arch cut-outs: Maximum 10mm over tire diameter.

9.4.8 1/10 Scale .15 Fuel Touring Car 2WD:

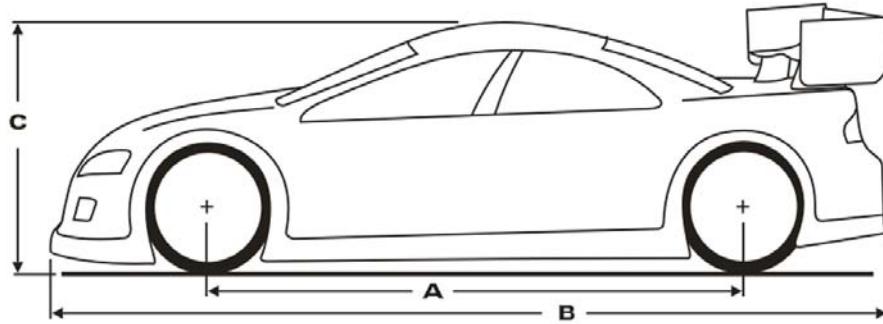

9.4.8.1 Dimensional Specifications:

Item		Limit	Specification	
Length (B)		Maximum	19.3"	
Width		Maximum	9.84"	
Height (C)		Minimum	4.5"	
Wheelbase (A)		Maximum	11.02"	
		Minimum	10.24"	
Weight		Minimum	64 ounces	
Wheels	Diameter	Maximum	2.0"	
		Minimum	1.625"	
	Width	Front	Maximum	1.18"
		Rear	Maximum	2.0"
Tires	Diameter	Front	Maximum	2.95"
		Rear	Maximum	3.15"
	Width	Front	Maximum	1.18"
		Rear	Maximum	2.01"
Rear Wing	Chord		Maximum	3.0"
	Width		Maximum	9.0"
	Side dam length		Maximum	3.75"
	Side dam height		Maximum	2.0"

9.4.8.2 Tire type: Foam only.

9.4.8.3 Engine size: .15 ROAR/IFMAR only

9.4.8.4 Transmission: Single or two-speed

9.4.8.5 Rear suspension and drive:

- Independent suspension allowed
- Rear wheel drive only

9.4.8.6 Body and Wing rules:

- Bodies must resemble a 2 or 4-door vehicle that has run in a full-size Touring Car series.
- Only one wing allowed; fitted in the same place as the wing on the original vehicle
- The wing must be fastened to the rear deck of the body, not to the chassis of the vehicle
- No part of the wing may extend above the roofline of the body.
- The rear of the body may not be cut out, and must retain the bumper molding lines.

9.4.8.7 Wheel arch cut-outs: Maximum 10mm over tire diameter.

9.4.9 1/8 Scale On-road Fuel (IFMAR Class):

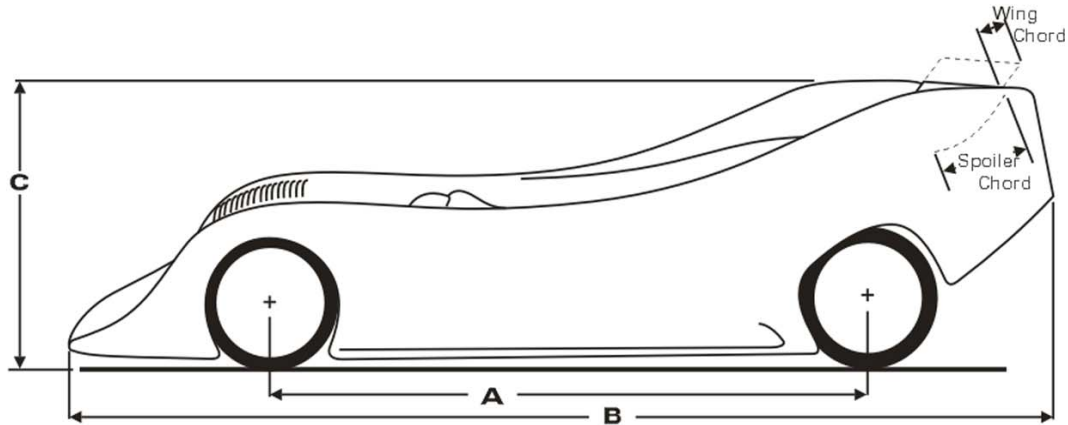

9.4.9.1 Dimensional Specifications:

Item		Limit	Specification
Length (B)		Maximum	637 mm
Width (see 9.4.9.8 below)		Maximum	267 mm
Height (C) to top of wing		Maximum	190 mm
Wheelbase (A)		Maximum	330 mm
		Minimum	270 mm
Weight	4WD class	Minimum	2525 g
	2WD class		2400 g
	Pan Class		2270 g
Wheels	Diameter	Maximum	54 mm
		Minimum	44.45 mm
	Width – Front	Maximum	37 mm
	Width - Rear	Maximum	64 mm
Tires	Diameter – Front	Maximum	N/A
	Diameter - Rear	Maximum	N/A
	Width – Front	Maximum	37 mm
	Width - rear	Maximum	64 mm
Rear Spoiler	Chord	Maximum	77 mm
	Width	Maximum	267 mm
Rear Wing	Chord	Maximum	78.75 mm
	Width	Maximum	267 mm
	Side dam length	Maximum	76.2 mm
	Side dam height	Maximum	38 mm

9.4.9.2 Tire type: Foam only

9.4.9.3 Engine size: .21 ci only

9.4.9.4 Transmission: Single, two or three-speed.

9.4.9.5 Rear suspension and drive:

- Independent suspension allowed
- 2WD or 4WD

9.4.9.6 Body style: Can-Am, Sports/GT, or WSC.

9.4.9.7 Wheel arch cut-outs: Maximum 13 mm over tire diameter

9.4.9.8 Upper body widths will be checked by placing a caliper or similar tool, legs down, across the top of the body at any point.

## **10 RULES FOR 1/5-SCALE FUEL CLASSES**

The following rules are additional rules for the 1/5-scale class. In most cases, the rules in this section are designed to further define the General Rules. Unless there is a stated direct override to a General Rule, the General rule applies.

### **10.1 BODY RULES – Sedan and GT**

- 10.1.1 All vehicle bodies used in ROAR-sanctioned events must be realistic 1/5-scale models of an existing full-size vehicle. No mixing of vehicle designs is allowed.
- 10.1.2 Bodies must be ABS plastic or lexan.
- 10.1.3 Bodies may not be reshaped (modified) from their original molding.
- 10.1.4 Bodies must cover the tires above their horizontal centerline when viewed from above.
- 10.1.5 Excessive “crash” damage must be repaired or the body replaced before the body shell will be allowed to compete in Level 3-5 events.
- 10.1.6 All bodies used in the STC class must be ROAR or IFMAR approved.
- 10.1.7 The Sports/GT and "Sportsman" classes may use any body that is within the written Specifications in 10.10 below and complies with rule 10.1.1 above.
- 10.1.8 Bodies must be painted except for window areas, which must be clear or open. No tinting of windows is allowed.
- 10.1.9 No holes other than those specifically allowed below are permitted unless they existed on the full-size vehicle, in which case the openings in the body must be accurate in scale and position relative to the full-size vehicle, to within 10%. The responsibility for proof of scale accuracy lies with the driver of the vehicle.
- 10.1.10 Antenna holes, body mounting holes, and exhaust outlet holes (max. .8 inch (20mm) larger diameter than the outlet pipe diameter) are allowed.
- 10.1.11 Windshields may not be cut out.
- 10.1.12 All window cutout(s) must be within the molded lines for the window areas, with the exception of the corners that may have a radius no larger than .75" measured from the corner.
- 10.1.13 Side windows may be cut out for cooling. It is not allowed to mold air channels into the side windows for cooling. When windows are cut out, they must be completely cut out in a single hole.
- 10.1.14 If the rear window is cut out, it must be completely cut out unless the cut out is only for access to the Shut-off Switch. In this case, a single hole may be cut out inside a rear window area, located to allow easy access to the Shut-off Switch.
- 10.1.15 Drilling or cutting a series of holes in windows is not allowed.

### **10.2 BODY RULES – Formula Cars**

- 10.2.1 All vehicle bodies used in ROAR-sanctioned events must be realistic 1/5-scale models of an existing full-size vehicle. No mixing of vehicle designs is allowed.
- 10.2.2 Bodies must be ABS plastic or Lexan.
- 10.2.3 Bodies may not be reshaped (modified) from their original molding.
- 10.2.4 Excessive crash damage must be repaired or the body replaced before the body shell will be allowed to compete in Level 3-5 events.
- 10.2.5 Bodies must be painted except for window areas, which must be clear or open. No tinting of windows is allowed.
- 10.2.6 All cutouts must exist also in the full size vehicle. Cuttings for engine and fuel tank are allowed in the area of the tank seal, starting device and adjusting screws for carburetor i.e. choke, neutral gear etc
- 10.2.7 Antenna holes, and body mounting holes are allowed.

### **10.3 BUMPER RULES – non-Formula Cars**

- 10.3.1 Front foam bumpers are mandatory. The foam bumper must extend 1.4 inches (35mm) past the hard chassis and/or plastic bumper on all sides. The minimum bumper height is 1.5 inches (40mm).

- 10.3.2 No inflexible material for body shell mounting may protrude from the body more than .4 inches (10mm).

## 10.4 ENGINE RULES

- 10.4.1 Only single-cylinder, two or four stroke, naturally aspirated, spark ignition engines equipped with pull-starters are allowed.
- 10.4.2 No Wankel-type, rotary valve, or fuel-injected engines are allowed.
- 10.4.3 The maximum displacement allowed is 1.4ci (23cc).
- 10.4.4 The engine case must be a single casting. The engine case must be factory-original. No billet-machined cases are permitted.
- 10.4.5 The cylinder and cylinder liner must be of one casting. No slip-in or independent liners (sleeves) allowed. Chrome plating or Nikasil coating of the cylinder bore is allowed.
- 10.4.6 The cylinder head may be a separate part machined from billet as long as the head is commercially available.
- 10.4.7 The maximum number of transfer ports (defined as the ports that allow the fresh air/fuel mixture into the combustion chamber) is limited to four (4).
- 10.4.8 The transfer ports must be open to the piston along their entire length in the cylinder. The piston must be used as the inner wall of the transfer port.
- 10.4.9 The side walls of the transfer ports must be parallel. No "lost wax casting" methods or other means may be used to provide "sweeping" side walls of the transfer ports.
- 10.4.10 The crankshaft must be of split-shaft configuration. No half crankshafts are allowed.
- 10.4.11 The connecting rod must be of one-piece construction.
- 10.4.12 The engine must be air-cooled by a flywheel-mounted fan.
- 10.4.13 Only passive ignition systems using one sensor (rpm) are allowed.
- 10.4.14 Ignition timing must be fixed. No mechanical timing advance/retard mechanisms allowed.
- 10.4.15 Resistor type spark plugs must be used. A metal-shielded resistor-type plug cap is recommended.
- 10.4.16 Variable exhaust timing/porting is not allowed.
- 10.4.17 Exhaust pipes with movable parts are not allowed. Sound eliminating fiber or like materials are not defined as moving parts within an exhaust system.
- 10.4.18 The maximum carburetor venturi diameter is .5 inch (13mm). An air filter must be fitted to the carburetor.
- 10.4.19 This rule only applies to ROAR level 3-5 events. There will only be two engines allowed for each class entered. These two engines must be checked in at the beginning of this event and logged for the class(s) in which they will be run. Only the primary of these engines may be used, for Qualifying as well as the Mains. The secondary engine may be used only in case of catastrophic failure of the primary engine. Catastrophic failure is defined by the primary engine being unable to operate. If the secondary engine is used, the damaged engine will be stored in technical inspection or other safe place until the end of the event. The engine used to set the driver's best qualifying time must be used in their main event. If the qualifying engine is deemed unable to operate prior to starting the mains, then the secondary engine will be allowed but the driver must start their main from the pit.

## 10.5 MUFFLER RULES

- 10.5.1 All vehicles raced at a ROAR-sanctioned event must be equipped with muffler that complies with the following specifications.
- 10.5.2 The muffler/pipe must be of a multiple chamber design with an internal or external silencer. The maximum inside dimension of the exhaust outlet pipe is .5 inches (13mm). On STC and Sports/GT vehicles, the muffler stinger may not extend more than .4 inches (10mm) outside of body. On Formula vehicles, the muffler stinger must exit within the body shell side pods and point down towards the track surface.

- 10.5.3 Maximum noise level allowed is 85 dB(A) measured at a 90 degree angle to the direction of travel of the vehicle at a distance of 33 feet, 3 feet above the ground, with the engine at maximum throttle and at all speeds. The Race Director may decide on a different method of noise measurement as long as the results are the same. If there is no noise level equipment available, the Race Director can decide whether a vehicle that produces a noise level in excess of other cars will be allowed to compete.

## **10.6 FUEL RULES**

- 10.6.1 Only unleaded 'corner gas station' automotive pump gasoline available to the general public may be used. The use of aviation or racing gasoline that is not street legal automotive pump gasoline is specifically prohibited unless the race is to be run with event-provided gasoline. For events where event-provided gasoline will be used, the octane and type of fuel must be disclosed on all advertisements and entry forms. An additional fee may be added to the entry fee to cover the cost of the gasoline. The Race Director or Technical Inspector can require any contestant to use event-provided gasoline at any time prior to racing.
- 10.6.2 The only additive allowed in the gasoline is mass-produced two-stroke oil. When event-provided gasoline is used, the type and percentage of the oil used in the fuel must be disclosed on all advertisements and entry forms.
- 10.6.3 Maximum fuel system capacity is 700cc, including fuel lines. The capacity of fuel tanks will be measured using either of the procedures specified in rule 9.2.8.3. During a post-main inspection only, a maximum tolerance of +1% (7cc) will be allowed in the tank size.

## **10.7 TIRE RULES**

- 10.7.1 Tires must be black and of semi-pneumatic rubber construction. Foam tires are not allowed.
- 10.7.2 Foam inserts are allowed.
- 10.7.3 Tire traction compounds, other tire chemicals/additives, or chemical tire cleaners are not allowed
- 10.7.4 New design, limited availability, or prototype tires may be banned from an event at the discretion of the Race Director.
- 10.7.5 In case of rain or other wet track conditions the use of rain tires may be allowed by the Race Director.

## **10.8 RADIO AND SERVO RULES**

- 10.8.1 Three channel radios are permitted, but the only functions allowed are steering, throttle, and brake.
- 10.8.2 No onboard traction control or other electronic aids are allowed, other than other than fail-safe systems.
- 10.8.3 A fail-safe radio/servo system is highly recommended, but not mandatory
- 10.8.4 It is highly suggested, but not mandatory, that separate battery systems be used, one for the radio receiver and a separate pack to power the control servos.

## 10.9 SAFETY RULES

- 10.9.1 No refueling is allowed after the warm-up period for a race has begun, and no refueling is allowed during the running of any Qualifier or Main event.
- 10.9.2 In the case of an unforeseen delay after the warm-up has started for a Main event only, the Race Director should impound the cars at a pre-disclosed location until such time that the cars have cooled to the point where they can be safely refueled. When the race is ready to be restarted, cars will be allowed another 3-minute warm-up prior to the start.
- 10.9.3 Vehicles should have a fail-safe system that will positively return the vehicle's throttle to an idle position if the vehicle loses electrical power or its radio signal.
- 10.9.4 It is NOT recommended that the receiver battery used in any vehicle have a higher voltage than the voltage listed in the manufacturer's specifications for the radio receiver or servos being used.
- 10.9.5 Vehicles must have brakes in good working condition. Brakes must be capable of stopping a vehicle from racing speeds and must be able to hold the vehicle motionless with the engine running.
- 10.9.6 A shut off switch must be fitted to all vehicles, and its position on the vehicle must be marked on the body by a 20mm diameter white circle bordered in red, containing the letter "E" in red, centered in the circle. This marking must be located next to the switch or the access hole for the switch and must be kept clean. For STC and Sports/GT cars, the switch must be located either in the rear window area, or accessible through the rear window if this is cut out. For Formula cars, the shut off switch must be accessible from the top of the vehicle with body on and clearly marked in accordance with this rule.

## 10.10 CLASS RULES

- 10.10.1 Vehicles are divided into two classes by body type:
- Super Touring Car (STC) (This is the official IFMAR World Championship class))
  - Sports GT (GT).
  - Formula Cars.
- 10.10.2 All classes may run together if there are insufficient entries to split into separate classes. Cars should not be split into separate classes if this will result in three or less cars running in a separate class.
- 10.10.3 For safety and cost control reasons, Formula cars should not be run at the same time as closed-wheel cars.
- 10.10.4 For Level 4 events, STC must be run as a separate class.
- 10.10.5 No "Stock" or "Sportsman" class is currently defined, as there is no general agreement on specifications for a "stock" engine. Race Organizers may define their own parameters for a 'stock engine environment' to suit a Sportsman class, such as 40 minute A-Mains. These parameters must be stated on the event's entry form and available to each entrant at the track.
- 10.10.6 Only the results of the Super Touring Car (STC) class will be used for the purposes of qualifying drivers for the IFMAR World Championships at qualifying events.
- 10.10.7 Transmission: Single speed only.
- 10.10.8 Rear suspension and drive:
- Independent suspension allowed
  - Rear wheel drive only

**Specifications:**

Item		Limit	10.10.9	10.10.10
			IFMAR Super Touring	Sports/GT
Width		Maximum	395 mm	
		Minimum	362 mm	
Width (at widest point of body, excluding mirrors)		Maximum		16.59"
Length		Minimum	798 mm	
Height (measured at 6mm ground clearance)		Minimum	248 mm	
Ground clearance (measured with 10kg weight added to vehicle)		Minimum	2.0 mm	
Ground clearance at normal ride height		Minimum		.236"
Weight (without fuel)		Maximum	12.0 kg	23.4 lbs.
		Minimum	9.5 kg	
Wheels	Diameter	Maximum	107 mm	4.2"
Tires	Diameter	Maximum	136 mm	5.35"
Tire/Wheel Assembly	Width - Front	Maximum	75 mm	2.95"
	Width - Rear		80 mm	3.15"
Wing: only one single-element, painted or opaque wing allowed, no dihedral angles.	Width	Maximum	300 mm	Body width
	Chord	Maximum	60 mm	3.35"
	Height above deck at centerline of vehicle	Maximum	60 mm	
	Side dam height	Maximum	60 mm	3.35"
	Side dam length	Maximum	60 mm	2.36"

**10.10.9 1/5 Scale Super Touring Car (IFMAR Class):**

10.10.9.1 Body and Wing rules:

- Bodies must resemble FIA Class 2 or Class N, four door cars only, with a minimum full scale length of 165.4 inches (4200mm)
- All dimensions must be within scale +/- 5% of the full-size vehicle represented.
- The body must cover the outer edge of the tires at the center of the axle when viewed from above.
- The leading and trailing edges of the wing must be parallel.

10.10.10 **1/5 Scale Sports/GT class:**

10.10.10.1 Specifications:

10.10.10.2 Body and Wing rules:

- Bodies must resemble full-size vehicles raced in GT1, GT2, GTS, ALMS, Trans-Am or American GT classes or similar.
- All dimensions must be within scale +/- 5% of the full-size vehicle represented.
- If there is doubt about the eligibility or dimensional accuracy of a body, it is the responsibility of the driver to provide proof of compliance with these rules.
- No part of the wing or side plates may extend above the roofline of the vehicle
- The leading and trailing edges of the wing must be parallel, except where proof is provided of a different shape on the full-size vehicle.



10.10.11 **1/5 Scale Formula class:**

10.10.11.1 Specifications:

Item		Limit	Specification
Width across outer edges of tires		Maximum	450mm
Width across widest point of side pods		Maximum	90% of actual width across tires
Side Pod height		Maximum	Level with the top of the front tires
Height (at 6mm ground clearance)		Maximum	250mm
Weight (without fuel)		Minimum	10,000g
Wheelbase		Maximum	635mm
		Minimum	605mm
Front overhang (ahead of front wheel centerline)		Maximum	230mm
Rear overhang (behind rear wheel centerline)		Maximum	120mm
Tires (see Note1)	Diameter	Maximum	149mm
		Minimum	135mm
Tires	Width – front	Maximum	75mm
		Minimum	60mm
	Width - Rear	Maximum	85mm
		Minimum	5mm wider than front
Wheels (see Note 2)	Diameter	Maximum	85mm
		Minimum	75mm
Wing - front	Width	Maximum	375mm
	Chord	Maximum	120mm
	Height	Maximum	Centerline of front wheels
Wing - rear	Side profile	Maximum	95mm wide X 120mm high
	Number of wing elements	Maximum	2
	Width	Maximum	Distance between inner edges of rear tires

**Note 1:** Front and rear tires must have the same diameter.

**Note 2:** No mixture of maximum and minimum tolerances on wheels and tires is allowed. If wheels are on maximum size, then tires may not be on minimum size, etc.

10.10.11.2 Body and Wing rules:

- Bodies must resemble full-size vehicles raced in Formula One, CART, IRL or similar open-wheel classes.
- All dimensions must be within scale +/- 5% of the full-size vehicle represented.
- If there is doubt about the eligibility or dimensional accuracy of a body, it is the responsibility of the driver to provide proof of compliance with these rules.
- The front wing assembly must be mounted to the chassis in such a way that it can bend up or down in case of an accident.
- Front wings are considered part of the body shell, and must therefore be repaired immediately should they be damaged or fall off the vehicle during a race.
- Rear wings may be removed if damaged, but are not required to be replaced during the race.
- All vehicles must start the qualifiers and mains with all wings present.

## 10.11 QUALIFYING RULES

- 10.11.1 Qualifiers will be 5 to 10 minutes in length with a 3-minute warm-up period.
- 10.11.2 A maximum of 10 cars per heat and main are allowed.
- 10.11.3 The number of qualifying rounds will be up to the Race Director, but a minimum of 3 rounds is suggested.
- 10.11.4 When an event is not a ROAR Level 3-5 event, a suggested method for qualifying would be: Begin the clock as an IFMAR style run. After a 3-minute warm-up period, sound a starting horn. At the end of the run sound a finish tone or horn. Highest number of laps in the shortest time will set the mains. The actual method of qualifying must be announced before qualifying begins.
- 10.11.5 If the event is a ROAR Level 3-5, the IFMAR qualifying method will be used.
- 10.11.6 The best two of three (3) qualifying rounds using the ROAR Qual-Points System will be used to set the mains.
- 10.11.7 The mains will be set with two (2) bump ups.
- 10.11.8 For other scoring system protocols, like single lap, scorekeeping deviations must be requested from ROAR. The main consideration at Level 3-5 events is the capability of the scorekeeping system to handle the type of qualifying desired. The (approved) scorekeeping system will be disclosed on all racing flyers and entry forms. At Level 5 events, the first place finisher in sub-mains will bump up to the next level. At Level 5 events, the top 9 qualifiers will automatically be placed in the A-Main.

## 10.12 RACING RULES

- 10.12.1 All races must be preceded by a 3-minute warm-up period.
- 10.12.2 A staggered standing start or rolling start in qualifying formation may be used at the discretion of the Race Director.
- 10.12.3 Races will be run using air horns, loudspeakers and/or flags to alert drivers of a caution situation.
- 10.12.4 Signal definitions:

Caution type	Horn/PA signal	Flag Signal	Action
1	Single 2-second blast	Green Flag	All clear, continue racing
2	Two 1-second blasts	Yellow Flag	Caution – slow driving required on all parts of the track
3	Three 1-second blasts	Red Flag	Stop immediately

- 10.12.5 Under a Caution #2 (Yellow flag) condition, all racers must bring their cars to a slow controllable speed and are not allowed to pass.
- 10.12.6 Under a Caution # 3 (Red Flag) condition, all racers must stop their vehicles immediately wherever they are on the track surface.
- 10.12.7 A Caution #2 or #3 (Yellow or Red Flag) condition must be called prior to anyone going onto the racetrack. No corner marshals or mechanics are allowed on the track during practice or racing without a caution being called. Marshals will wait until race vehicles come to a slow, controlled pace before entering racing area. Track maintenance must be done under a caution condition.

## 10.13 PENALTIES

- 10.13.1 Rough driving, or passing under a Caution #2 (Yellow Flag) will incur a ten-second stop-and-go penalty. A second offense may result in disqualification at the discretion of the Race Director.
- 10.13.2 Failure to obey a Caution #3 (Red Flag) will result in disqualification from the race in which the offense occurred.

# 11 IFMAR WORLD TEAM RULES

## 11.1 GENERAL

- 11.1.1 The International Federation of Model Auto Racing (IFMAR) is the sanctioning body for all World Championships (WC). ROAR is one of four voting member Blocs of IFMAR, the others being the European Federation of Radio Controlled Automobiles (EFRA), the Far East Model Car Association (FEMCA) and the Fourth Association of Model Auto Racing (FAMAR). ROAR is the only organization in Canada and the United States entitled to send drivers to a WC.
- 11.1.2 IFMAR WC events are held for electric and fuel cars on off-road and on-road tracks. Individual events are held every other year, and normally rotate between EFRA, FAMAR, FEMCA, and ROAR.
- 11.1.3 Entries are limited to 150 drivers or less. ROAR is normally allocated 30 entries for each WC, and may receive additional entries if these are not used by the other blocs. Entries not used by ROAR are returned to IFMAR for reallocation.

## 11.2 SELECTION POLICY

- 11.2.1 ROAR has adopted a general policy for selecting the members of a WC team. Those eligible for the team include:
  - 11.2.1.1 All ROAR member drivers who raced the Main event at the previous WC in that class, and
  - 11.2.1.2 The top finishers (the exact number depends on the number of pre-qualified drivers from the prior WC) in that class from the previous year's ROAR Nationals.
- 11.2.2 If ROAR events other than ROAR Nationals are to be used to qualify drivers for the ROAR WC Team, those events will have secondary priority to ROAR National events.
- 11.2.3 If more than one class is run at a WC, as is the case with 2WD and 4WD off-road, the team will consist of the A main drivers in both classes from the previous WC and the top finishers in those classes at the previous year's ROAR Nationals. These positions will be allocated based on the number of entries in the two classes at the ROAR Nationals.
- 11.2.4 Drivers qualified for a WC must keep their membership current or they will lose their eligibility.
- 11.2.5 Since there are normally some drivers who are eligible, but not able, to attend the WC, a system for selecting alternates has been established. Any driver wanting to be considered as an alternate may send a resume of racing experience to the appropriate IFMAR representative (Fuel or Electric) as announced in the ROAR Rev-Up newsletter or posted on the ROAR web site. Selection of alternates will be based on racing experience, and will take place after the deadline for primary entries has expired. Primary consideration for alternate status on a World Championship Team will be given applicants that have won first place in the appropriate class at their Regional event.

## 12 NATIONALS POLICIES

### 12.1 GENERAL

- 12.1.1 The National Championship events are the premier ROAR events. They are governed by the rules contained in this book and by specific rules contained in the Nationals Guidelines.
- 12.1.2 Only National Championship events confirmed by the ROAR Executive Committee are allowed to use the term "ROAR Nationals" in their promotional efforts. All advertising must state "<Year> ROAR <Class> Nationals". Sponsors or other co-hosts may be referred to as such, but the event must be clearly billed as the "ROAR Nationals" and cannot be referred to in conjunction with any sponsor, manufacturer, or another event.
- 12.1.3 The ROAR Executive Committee must approve any deviations from the National Guidelines or ROAR Rules. The ROAR National Guidelines are available from the ROAR Administrator or may be downloaded from the [www.roarracing.com](http://www.roarracing.com) website, and may be used by any member track wanting to conduct races using the National's format. National Policies (in this rulebook) and/or the current year's ROAR National Guidelines may supersede other rules in this rulebook.
- 12.1.4 **Site selection:** The importance of these events makes site selection critical to their success. The process begins with each Class Committee's solicitation for bids. The Class Committee(s) will select the site and Organizer and submit their recommendations to the ROAR Executive Committee for final approval. The Organizer must be a current ROAR club or track with experience in holding large racing events under ROAR rules.
- 12.1.5 The Executive Committee will meet in the early Fall to make the final site confirmations. These will be based on the recommendations of the Class Committees.
- 12.1.6 To provide the widest possible exposure and opportunity to compete, the location of the individual National events will be rotated as much as possible.
- 12.1.7 In selecting Nationals sites, the Class Committees must make every effort to avoid having the same Nationals, or any other Nationals, at the same location two years in a row. ROAR will try to avoid using the same location on a repetitive basis.
- 12.1.8 The ROAR Executive Committee will designate the classes and scales that will receive the National Championship designation. IFMAR world championship classes will be the main basis for selecting required classes. Other classes or scales may be offered in support of the event, but will not receive National Championship designation unless pre-approved by the ROAR Executive Committee.
- 12.1.9 If it appears that a National event for a specific class has become more of a regional event, the ROAR Executive Committee may consider the elimination of National Championship status for that class.
- 12.1.10 Local procedures and rules that conflict with ROAR rules are not allowed.
- 12.1.11 The official race results will be made equally available to all media upon request.

## 12.2 ENTRY RULES

- 12.2.1 The maximum number of classes that may be entered by an individual driver at a single Level 5 event is three, unless otherwise indicated in the National Guidelines.
- 12.2.2 At any single Level 5 event, a driver may not enter the stock class and another class for the same vehicle type.
- 12.2.3 A maximum of six classes may be offered at any single National event. These classes must be applied for by the Host Club in their bid for the event, and must be published on all advertising, and on the event entry form.
- 12.2.4 Juniors', Masters', Demonstration and Provisional classes may be included as long as the six class limit is not exceeded.
- 12.2.5 **Definitions and Restrictions:**
  - 12.2.5.1 Juniors are drivers age 15 or under on the final day of the race. Proof of age will be required.
  - 12.2.5.2 Minimum Masters drivers' age is 45 for fuel on road classes. All others must be age 40 or above as of the first day of qualifying. Proof of age is required.
  - 12.2.5.3 Juniors and Masters may enter other classes, but not in the same type vehicle.
  - 12.2.5.4 Provisional and Demonstration classes are defined in rule 5.3.1.8.
- 12.2.6 Entries may not be transferred from one driver to another without the express permission of the Race Director.
- 12.2.7 If the Stock Off-road Nationals precede the Modified Off-road Nationals for a given calendar year, any driver who finishes in the top 10% (rounded up) of a required class will be barred from entering the Modified Nationals (Juniors and Masters not included). Drivers who are currently qualified for an IFMAR WC or have participated in either of the two previous off-road WC may not enter this event.
- 12.2.8 If the Modified Nationals precede the Stock Nationals for a given calendar year, any driver who finishes in the top 20% (rounded up) of any class will be barred from entering the Stock Off-Road Nationals.

## 12.3 RACING RULES

- 12.3.1 The specific Nationals track layout will not be run on prior to the race except for a minimum of two and a maximum of four days prior to the event. Permanent (non-adjustable) on-road courses and oval tracks of all surfaces may be excluded from this rule.
- 12.3.2 Qualifying will use IFMAR Starts. On a track with low lap times, starting will be by rows.
- 12.3.3 All cars must cross the timing loop prior to the start of every race to verify correct transponder operation and proper vehicle numbers.
- 12.3.4 Personal transponders will be required at level 5 races. These must be uniquely numbered per driver. No sharing of PTs between drivers is allowed, although an individual driver may use a single PT for all vehicles entered.
- 12.3.5 Except for Carpet On road, Oval, and 1:5 scale events, qualifying will be based on the ROAR Qual-Points System. Oval and 1/5 scale events will use each entrant's single fastest laps/time in a heat to determine the qualifying order.

### **12.3.6 ROAR Qual-Points system:**

- 12.3.6.1 Under this system, the Top Qualifier in each round gets zero points, second gets two points, third gets three points, etc., increasing by one point per position.
- 12.3.6.2 The final Qualifying order will be determined by the sum of each driver's best two rounds' points.
- 12.3.6.3 First level ties will be broken by the sum of the laps/time results of the tied drivers' best two points rounds. Thereafter if ties still exist, these will be broken by the best single laps/time result for each driver, regardless of the round in which it was recorded.
- 12.3.6.4 In cases where only two rounds of Qualifying could be completed, the final Qualifying order is based on the single best points, with points from the second best round being used as the first level tie breaker, and the total laps/time for the two rounds being used as the second level tie breaker.

### **12.3.7 Main Events:**

- 12.3.7.1 There will be a minimum of 10 drivers in the A Mains.
  - 12.3.7.2 Except for Oval racing, a triple A Main system will be used for all electric classes, including Juniors and Masters classes, if offered. A single Main event will be used for all lower Mains, as well as for the A Mains of Oval events.
  - 12.3.7.3 The final results of a triple A-Main event will be decided by a point system based on ten (10) points for the winner of each individual Main on down to one (1) point for the tenth placed finisher in each individual Main. The total of each driver's best two (2) out of three (3) Mains points will count. The tiebreaker will be the total laps and times of the best two (2) Mains which were counted.
  - 12.3.7.4 A driver who wins the first two mains of a triple A Main event must sit out of the third Main.
  - 12.3.7.5 Any deviation from this format must be approved by the ROAR Executive Committee in advance.
- 12.3.8 The finishing order of the race will be determined by the order in which the cars reach the finish line. This will take precedence in the event there is a conflict with the results reported by the computer. The fact that a vehicle crosses the finish line outside the limits of the racing line will not be cause for a penalty unless it results in an advantage over another vehicle. A Race Official is required to observe and record the order of the finish of all A-Mains.
- 12.3.9 If a race is interrupted by weather before it reaches the halfway point then the cars are returned to the entrants and the race is restarted in qualifying order, one second apart, from the pits when weather permits. If the interruption is after the halfway point then the race is considered complete and the results will be based on the last completed lap for each driver at that time.

## **12.4 EQUIPMENT USAGE RULES**

- 12.4.1 Only ROAR-approved electric motors, batteries and bodies may be used in National Championship events. Motors, batteries, and bodies must have been listed in the Rev-Up newsletter, or on [www.roarracing.com](http://www.roarracing.com) fourteen (14) days prior to the event to be eligible for use.
- 12.4.2 If deemed necessary by the Executive Committee, equipment used in Provisional or demonstration classes or scales may be excluded from the fourteen-day requirement.
- 12.4.3 Vehicles, parts, and accessories used in Stock electric classes must be readily available through retail outlets at least 14 days prior to the event.
- 12.4.4 Vehicles must pass a minimum tech inspection prior to and/or after every race. Illegal cars will not be allowed to run. A minimum tech inspection consists of but is not limited to: vehicle dimensions, weight, proper engine/motor, legal body, assigned frequency (except

in the case of 2.4GHz DSS systems) and vehicle number. The Race Director, Technical Inspectors or the Designated ROAR Official may call for inspections at any time.

12.4.5 Tire traction chemicals or other chemicals that emit odors that could be offensive or are labeled as hazardous should not be permitted at indoor events or in pits that are indoors. Use of traction compounds at any ROAR event is at the discretion of the Race Director and any/all bans or special requirements must be disclosed in advertising and on race entry forms.

#### 12.4.6 **HANDOUT MOTOR RULES**

12.4.6.1 Handout motors will be used in all stock electric classes. The term "Handout Motor" includes the following components:

- Cans
- End bells
- Brush hoods
- Bushings
- Armatures

12.4.6.2 All handout motors will be right hand drive only.

12.4.6.3 Drivers may not use their own stock motors or stock motor components when the event requires that Handout motors be used.

12.4.6.4 Bushings may not be cut or modified in any type of Handout motor.

12.4.6.5 There is no requirement to impound stock motors overnight. If this is done, drivers must be informed of this when they are issued their motors for the first time.

#### 12.4.7 **HANDOUT TIRE RULES**

12.4.7.1 The following classes are defined as requiring handout tires at Level 4 events:

- Off-Road classes except Modified, Provisional or Demonstration classes
- All Electric Touring Car pavement classes.
- All Electric Touring Car carpet classes when rubber tires are specified.
- All Electric Paved Oval classes at tracks requiring capped tires

12.4.7.2 Handout tires are allocated to the vehicles entered, and not to the drivers.

12.4.7.3 Tire sets or pairs may not be exchanged between a driver's entries, or with another driver.

12.4.7.4 Handout Procedure:

- The Host picks the tires to hand out. Any business agreement is between the host and the tire's provider, not ROAR. If necessary, the host should make sure that returns will be taken by the tire provider for unsold tires.
- Tires must have a permanent visible stamp or manufacturer mold mark identifying them as handouts.
- For control purposes, the tire provider should ship the handout tires and inserts, or the tire/insert/wheel combinations (if pre-built assemblies are used), directly to the host track.
- If the handout tire and insert assemblies are not pre-built, drivers must mount their handout tires and return the completed assemblies to technical inspection. Technical inspection will permanently mark the wheels with the driver's vehicle entry ID number and tire set number. Drivers may use their own inserts.

- If the handout tire assemblies are pre-built, Technical Inspection must mark the wheels with each driver's vehicle entry ID number and tire set number before the set is given to the driver. Drivers may not use their own inserts.
  - Technical Inspection must keep records of handouts at registration and must control further handout purchases, where allowed.
  - Modifications to handout tires, apart from normal wear and tear, are not allowed.
- 12.4.7.5 One set of "free" Handouts must be included for each entry fee. A set of tires consists of all four (2 pairs) tires.
- 12.4.7.6 Additional tire purchases (non-Oval classes):
- Qualifying: In addition to the "free" set, drivers may purchase one set of tires per entry for use during Qualifying and/or the subsequent Mains.
  - Mains: In addition to the "free" set and the one extra Qualifying set, drivers may purchase one set of tires per Main for each vehicle entered, to a maximum of two extra sets. These tire sets may be purchased after the end of Qualifying and before the start of the Main events for the relevant class.
  - Drivers are limited to a maximum of four sets of tires for vehicles qualified for triple A-Mains, and to a maximum of three sets of tires for vehicles qualified for all single Mains.
  - The minimum purchase allowed is 1 tire pair (1/2 set), as long as the driver is within his 'number of sets' limit.
- 12.4.7.7 Additional tire purchases (Oval classes only):
- In addition to the "free" set, drivers may purchase a maximum of two extra sets of tires for each vehicle entered. These sets may be purchased at any time from the beginning of the event.
  - Drivers are limited to a maximum of three sets of tires per vehicle entered.
  - The minimum purchase allowed is one tire, as long as the driver is within his "number of sets" limit.
  - Drivers are required to run designated tire compound and stagger on specified location for the event. (i.e. if a blue standard is specified for the left front and a green right is specified for the right front, then you may not swap location of either tire.)
  - Tires designated per entry must remain with that entry. (i.e. if you are entered in 1/10 19T and 1/10 stock then you must run your 19T tires only on your 19T chassis. Stock entry must have its designated set of tires as well).
  - Drivers after being issued of one complete set of tires (4 initial tires per entry) may purchase one tire at a time up to two complete sets prior to the mains. Additional single or sets of tires for mains maybe purchased according to published rules.
- 12.4.7.8 No substitutes or exchanges can be made for any unused tire, pair or set of tires.
- 12.4.7.9 Technical inspectors will check each vehicle for proper driver/vehicle ID/Tire number(s). Inserts do not need to be checked. Vehicles without proper handout tires will not be allowed to run.
- 12.4.7.10 There is a one-lap penalty from the qualifier or main just run for use of an illegal, unregistered or otherwise improper tire.



## 13 CONOURS RULES

### 13.4 GENERAL

- 13.4.5 These rules establish a consistent basis for judging cars entered in a Concours d'Elegance competition.
- 13.4.6 Concours may be divided into two divisions; Best Appearing and Most Authentic. The Best Appearing category is for original designs and workmanship, not copies of full-size cars. The Most Authentic category is for scale representation of full-size racecars. The number of categories and awards is at the discretion of the Race Director.
- 13.4.7 A committee of three judges should be used to determine the winners. A judge may not have a vehicle entered in the Concours. Each judge shall independently score each vehicle. Each category shall be awarded a maximum of ten points. A perfect vehicle would receive ten points in each category. The cars are scored based upon comparative judging from among all the cars entered. Judges should take into consideration the difficulty of hand painted and hand crafted parts versus store bought decals, stickers, tape, or other items. The highest scoring entry will be the winner, the second highest scoring entry will be awarded second place and so on.
- 13.4.8 To qualify for an award, trophy winners in the Best Appearing category must race their cars in a main or qualifier following the judging. Any item attached to the body, and used in the determination of a score, must remain on the vehicle. Wings, drivers, and bodies cannot be changed. Motors, tires, rims, and batteries can be changed.
- 13.4.9 Winning cars are not allowed to compete in another ROAR Concours event regardless of event level. To ensure this, winning cars should be marked or otherwise identified by the judging Committee and this identification included in the race results of the event.
- 13.4.10 Suggested Concours scoring sheets are included in Appendix C, on pages C-1 and C-2.
- 13.4.11 Ties should be broken by choosing the vehicle with the highest point total in a category. The order of selection is: (1) Overall Effect; (2) Detail; (3) Paint; and (4) Body Preparation. For the Most Authentic division, authenticity should be the first tiebreaker, ahead of overall effect.

### 13.5 CATEGORIES FOR BEST APPEARING

- 13.5.5 OVERALL EFFECT:
- Does the package blend together well?
  - Is it visually appealing or gaudy?
  - Does the paint scheme fit the body style?
- 13.5.6 DETAIL:
- Are decals neatly trimmed?
  - Are decals hand painted?
  - Are decals on straight?
  - Are decals appropriate to the class?
  - Is the driver's cockpit fully detailed?
  - Is the interior painted?
- 13.5.7 PAINT:
- Does the paint bleed through in any areas?
  - Are multiple colors used?
  - Is it a simple or complicated paint scheme?
  - Is striping straight?

**13.5.8 BODY PREPARATION:**

- Is it neatly trimmed?
- Are the edges sanded and radiused?
- Are the wheel openings centered?
- Are the modifications made to the body inventive and well done?

**13.6 CATEGORIES FOR MOST AUTHENTIC**

13.6.5 These are the same as the Best Appearing criteria with the addition of one element – authenticity. Entrants in this category must provide photographic evidence of the full-sized vehicle being replicated.

**13.6.6 AUTHENTICITY:**

- Are photographic documents included?
- How does the entry compare to the documents?
- Does the overall package blend well together?
- Are there items included, such as wheels, motor, mirrors, antennas, driver, lights, etc., that add to the authenticity?

13.6.7 Vehicles entered in this category must be operational, but do not have to be raced. Operational is defined as being able to operate under its own power and in full control from the transmitter, without direct connection or outside aid.

**13.7 CONCOURS SCORE SHEET**

<b>Event name:</b>		<b>Date:</b>	
<b>Judge Name:</b>		<b>Category/Class:</b>	

Scores (1-10)							
Car #	Entrant name	Overall effect	Detail	Paint	Body preparation	Authenticity	Total

**NOTE:** The Authenticity element is used in determining the Most Authentic Winner only. Other categories are judged on the first four elements only.

# PROTEST FORM

<b>Event:</b>		<b>Date:</b>	
<b>Class:</b>	<b>Heat :</b>	<b>Round:</b>	
<b>Protest type:</b>	<b>Scoring:</b>	<b>Procedure:</b>	<b>Rule:</b>
			<b>Equipment:</b>

<b>Statement:</b>			
<b>Driver's name:</b>		<b>ROAR Number:</b>	
<b>Driver's signature:</b>		<b>Fee Included:</b>	\$

<b>Race Director:</b>		<b>Time of Protest:</b>	
<b>Ruling:</b>	<b>Protest upheld:</b>	<b>Protest rejected:</b>	
<b>Reason:</b>			
<b>Race Director's Signature:</b>		<b>Date:</b>	<b>Time:</b>

<b>Protest escalated to Designated ROAR Official:</b>	<b>Yes:</b>		<b>No:</b>	
<b>Ruling:</b>	<b>Protest upheld:</b>		<b>Protest rejected:</b>	
<b>Reason:</b>				
<b>DRO Name:</b>		<b>DRO Office:</b>		
<b>DRO Signature</b>		<b>Date:</b>		<b>Time:</b>